



PRODUCT CATALOG

V0125

AMERICAN LUBRICATION EQUIPMENT CORP.

2

OIL PUMPS & PACKAGES

- 2 ARO Thunder Oil Pumps
- 4 Thunder 3:1 Tapper Pumps
- 5 ARO 1:1 Transfer Pumps
- 6 ARO AFX Oil Pumps
- 8 Portable Oil Equipment

32

HOSE REELS

- 32 Advantage Plus Series
- 34 Advantage² Plus Series
- 36 Platinum Series Premium Double-Arm
- 38 Advantage Plus Cabinet Enclosure
- 39 Three-Reel Stand, Connecting Hoses & Hose Stops

12

GREASE PUMPS & PACKAGES

- 12 ARO Thunder 50:1 Grease Pumps
- 14 ARO AFX Grease Pumps
- 16 Portable Grease Equipment

40

CONTROL VALVES & METERS

- 40 Pro Series Digital Control Valves
- 42 Pro Series Mechanical Control Valves
- 44 900 Series Digital Preset Meters
- 46 Mechanical Preset Meters
- 47 In-Line Meters
- 48 760 Series Non-Metered Control Valves
- 50 ARO Non-Metered Control Valves
- 51 Oil Control Valve Accessories
- 52 Grease Control Valves & Swivels
- 53 Grease Couplers & Whip Hoses

18

DIAPHRAGM PUMPS

- 18 ARO 1/2" - 2" Diaphragm Pumps
- 20 ARO Diaphragm Drum Pump Packages
- 21 Diaphragm Pump Packages

54

OIL BARS & TAPPERS

23

PUMP ACCESSORIES

- 23 Connecting Hose & Pressure Relief Kits
- 24 Suction Tubes & Inlet Check Valves
- 25 Bung Adapters, Air Motor Mufflers & Mounting Brackets
- 26 Mounting Bracket Kits & Siphon Tubes
- 27 Drum Covers & Drum Tie-Down Kits
- 28 Lifts, Follower Plates & Dollies

56

FLUID INVENTORY CONTROL SYSTEMS

- 56 Fluid Inventory Control Systems
- 57 Accessories

29

DRUM ACCESSORIES

58

WASTE OIL EQUIPMENT

30

HAND-OPERATED DRUM PUMPS

- 58 Self-Evacuating Waste Oil Drains
- 59 24-Gallon Conventional Waste Oil Drain
- 60 Self-Evacuating Waste Oil Extractors
- 61 Oil Sink & Polyethylene Drains

- 62 Replacement Bowls
- 63 Accessories

66 TANK PACKAGES

- 66 Tank Packages
- 68 Tank Specifications
- 70 Roth Tank Packages
- 72 Stackable Poly Tanks
- 76 Tote Pumping Systems
- 78 Accessories

81 QUICK-LUBE EQUIPMENT

82 AIR SYSTEM COMPONENTS

- 82 Filters, Regulators & Lubricators
- 84 Air Couplers & Connectors
- 85 Accessories

86 INSTALLATION ACCESSORIES

- 86 Shut-Off Valves
- 87 Straight, 90° & 45° Union Adapters
- 88 Adapters & Reducing Bushings

89 HOSES

- 89 Air & Water Connecting & Delivery Hoses
- 90 Oil Connecting & Delivery Hoses
- 91 Grease Connecting & Delivery Hoses

92 GREASE GUNS

- 92 Hand-Operated Grease Guns
- 93 Accessories

95 GREASE FITTINGS

- 95 1/8" PTF, 1/4"-28 & 1/4" PTF Fittings
- 96 Stainless Steel & Metric Fittings
- 97 Thread Forming & Drive-Type Fittings
- 98 Buttonhead, Vented, Relief & Leakproof Fittings
- 99 Grease Fitting Assortments

100 DEF EQUIPMENT

- 100 Electric Pump Packages
- 102 Air-Operated Pump Packages
- 104 Bare Pumps & Hand-Operated Drum Pumps
- 105 Hose Reel, Meter & Control Handles
- 106 Mounting Brackets, Couplers & Downtubes
- 107 Adapters & Accessories

108 WARRANTY

ARO THUNDER OIL PUMPS



RELIABLE DESIGN

Thunder pumps feature a patented, ice-free air motor contained in a rugged housing that is designed to withstand the harshest working environments.

NO MECHANICAL ASSIST

Thunder's patented valve design uses no trip rods, push pins, or springs. Thunder has two (2) independent 3-way spool valves which work together to change the direction of the pump piston

FEWER PARTS

Thunder pumps are constructed with 50% fewer parts than the majority of comparable pumps



LM2305A-11-B

LUBE-FREE AIR MOTOR

The air valves and the piston are pre-lubricated. Thunder pumps do not require an air line lubricator

COST-EFFECTIVE DESIGN

Thunder's revolutionary design, inexpensive rebuild kits, and field serviceability all add up to a pump that has the lowest cost of ownership in the lubrication equipment market

IN-LINE SERVICE

Thunder pumps can be serviced in the tank or drum using just a standard wrench

3:1 SPECIFICATIONS

Air Inlet	1/4"(F)
Air Inlet Pressure	0 to 150 PSI
Air Motor Diameter	2"
Cycles per Gallon	37
Double-Acting	Yes
Fluid Inlet (Stub)	3/4"(F)
Fluid Outlet	1/2"(F)
Free Flow Rating	9 Gals/Min
Noise Level @ 100 PSI	80 db
Ratio	3:1
Stroke	3"
Working Flow Rating	6 Gals/Min
Rebuild Kit Part Number	637224

5:1 SPECIFICATIONS

Air Inlet	1/4"(F)
Air Inlet Pressure	0 to 150 PSI
Air Motor Diameter	3"
Cycles per Gallon	28
Double-Acting	Yes
Fluid Inlet (Stub)	1-1/2"(F)
Fluid Outlet	1/2"(F)
Free Flow Rating	9 Gals/Min
Noise Level @ 100 PSI	85 db
Ratio	5:1
Stroke	3"
Working Flow Rating	6 Gals/Min
Rebuild Kit Part Number	637226

FLUID COMPATIBILITY



Automatic Transmission Fluid



Gear Oil



Hydraulic Oil



Motor Oil



Synthetic Oil

ARO THUNDER OIL PUMPS STUB PUMP MODELS



3:1 PUMPS

	LM2203A-11-C	LM-2203A-C	LM-2203A-H	LM-2203A-HWM
Air Coupler	—	210	210	210
Air Connector	—	2608	2608	2608
Air Hose	—	—	AIR-HP1414-3	AIR-HP1414-3
Material Hose	—	—	TIM-4418-4S	TIM-4418-4S
Wall Bracket	—	—	—	TIM-460-A
Suction Hose	—	—	—	TIM-4416-8
Filter/Regulator	—	—	—	P-39224-624

5:1 PUMPS

	LM2305A-11-B	LM-2305A-C	LM-2305A-H	LM-2305A-HWM
Air Coupler	—	210	210	23902-210
Air Connector	—	2608	2608	MSCF22-000
Air Hose	—	—	AIR-HP1414-3	AIR-HP1414-3
Material Hose	—	—	TIM-4418-4S	TIM-4418-4S
Wall Bracket	—	—	—	TIM-460-A
Suction Hose	—	—	—	TIM-4416-8
Filter/Regulator	—	—	—	P-39224-624

STUB PUMP INSTALLATION PACKAGES

LM-2203A-COMP

Complete 3:1 Stub Pump Installation Kit

Includes *LM-2203A-H* stub pump, *P-39224-624* air filter/regulator and gauge, *TIM-212-1* nipple, *TIM-196-C* check valve and *PR-750* pressure relief kit

LM-2305A-COMP

Complete 5:1 Stub Pump Installation Kit

Includes *LM-2305A-H* stub pump, *P-39224-624* air filter/regulator and gauge, *TIM-212-1* nipple, *TIM-166-LLC* low-level cutoff and *PR-750* pressure relief kit



LM-2305A-COMP

TANK & DRUM PUMP MODELS

3:1 PUMPS



LM-2203A-41C

[LM-2203A-31C](#)

3:1 Pump for 16-Gallon Drum
(includes inlet check valve)

[LM-2203A-41C](#)

3:1 Pump for 55-Gallon Drum
(includes inlet check valve)

[LM-2203A-51C](#)

3:1 Pump for 275-Gallon Obround Horizontal Tank
(includes inlet check valve)

[LM-2203AV-61C](#)

3:1 Pump for 275-Gallon Obround Vertical Tank
(includes inlet check valve)

5:1 PUMPS



LM-2305A-41B

[LM-2305A-31B](#)

5:1 Pump for 16-Gallon Drum
(includes low-level cutoff)

[LM-2305A-41B](#)

5:1 Pump for 55-Gallon Drum
(includes low-level cutoff)

[LM-2305A-51B](#)

5:1 Pump for 275-Gallon Obround Horizontal Tank
(includes low-level cutoff)

[LM-2305AV-61B](#)

5:1 Pump for 275-Gallon Obround Vertical Tank
(includes low-level cutoff)

THUNDER 3:1 TAPPER PUMPS



VERSATILE

If your customer's needs change, just remove the taper and the pump can be used for pumping to remote overhead reel applications

COMPLETE PACKAGE

All taper pump packages include 3:1 pump, bung adapter, air filter/regulator, air coupler, air connector and taper valve assembly



TIM-728-2

TAPPER

*All taper packages includes a rugged, heavy-duty taper assembly with a splash-reduction adapter. Part number **TIM-724-1B** (tapper only)*

STUB PUMP MODEL

TIM-728-2

Stub Pump Tapper Package

Includes Thunder 3:1 pump, bung adapter, 1/4" nipple, P-39224-624 air filter/regulator/gauge, air coupler, air connector and oil dispensing tapper valve assembly

55-GALLON MODEL

TIM-726-2

55-Gallon Tapper Package

Includes Thunder 3:1 pump, bung adapter, downtube, 1/4" nipple, P-39224-624 air filter/regulator/gauge, air coupler, air connector and oil dispensing tapper valve assembly

275-GALLON MODEL

TIM-727-2

275-Gallon Tapper Package

Includes Thunder 3:1 pump, bung adapter, downtube, 1/4" nipple, P-39224-624 air filter/regulator/gauge, air coupler, air connector and oil dispensing tapper valve assembly

TAPPER KIT



TIM-724-1B

Tapper Kit

1/2"(M) end. 1,015 PSI (70 bar) pressure rating, compatible with oil and hydraulic oil

SPIGOT REPAIR KIT

TIM-OILSPIGOT-KIT

Oil bar (TIM-5-A2) and tapper spigot (TIM-724-1B) repair kit. Kit includes: O-rings, black steel roll pin, outlet gasket/seal.

ARO 1:1 TRANSFER PUMPS



RELIABLE DESIGN

ARO 1:1 pumps feature a proven design. They are constructed with fewer parts. Fewer parts means less problems

DOUBLE-ACTING

All ARO 1:1 piston pumps are double-acting, ensuring high flow rates



612041-3

LONG STROKE PISTON

Pumps feature a 6" long stroke design to ensure smooth delivery

DIVORCED DESIGN

These pumps incorporate a divorced design. The air motor is isolated from the lower pumping assembly. This assures that the materials being pumped do not contaminate the air motor

SPECIFICATION

Air Inlet	1/4"(F)
Air Inlet Pressure	0 to 150 PSI
Air Motor Diameter	2"
Double-Acting	Yes
Fluid Outlet	3/4"(F)
Free Flow Rating	18 Gals/Min
Pump Style	Divorced Design
Pump Material	Carbon Steel and Aluminum
Ratio	1:1
Stroke	6"
Working Flow Rating	9 Gals/Min

REBUILD KIT

Air Motor	637084
Fluid Section	637083

FLUID COMPATIBILITY



Automatic
Transmission Fluid



Gear Oil



Hydraulic Oil



Motor Oil



Solvents*



Synthetic Oil

* This pump is compatible with many solvents. Please call American Lubrication for specific solvent compatibility recommendations.

ARO AFX OIL PUMPS



NEW & IMPROVED DESIGN

AFX pumps feature a new innovative and simplistic design with universal parts without sacrificing the reliability of the legacy models

LUBE-FREE AIR MOTOR

AFX Series air motors are self lubricated and do not require an air line lubricator

9:1 RATIO

ARO AFX 4-1/4" oil pumps are ideal in systems requiring long piping runs



AF0409A13PFL1

HEAVY-DUTY CONSTRUCTION

The AFX Series oil pumps are designed for long distance, heavy viscosity oils, industrial installations and cold weather applications

MUFFLER

AFX Series pumps include a muffler which can also be ported to a remote location for quieter operation

STRESS-FREE PERFORMANCE

4" stroke and easy 19.2 cycles per gallon dispensing rate lead to a long service free pump life

SPECIFICATIONS

Air Inlet	1/2"
Air Inlet Pressure	0 to 150 PSI
Air Motor Diameter	4-1/4"
Double-Acting	Yes
Fluid Inlet (613100-1)	Barbed
Fluid Inlet (Stub)	2"(F) or 1-1/2"(M)
Fluid Outlet	3/4"
Fluid Outlet (613100-1)	3/8"
Free Flow Rating	18.1 Gals/Min
Ratio	9:1
Ratio (AF0409C81BBW2)	10:1
Stroke	4"
Working Flow Rating	3.9 Gals/Min

9:1 FLUID COMPATIBILITY

		
Automatic Transmission Fluid	Gear Oil	Hydraulic Oil
		
Motor Oil	Synthetic Oil	

9:1 REBUILD KIT

Air Motor Service Kit	637489
Packing Kit	637486

ARO AFX 9:1 OIL PUMPS

OIL PUMP MODELS



AF0409A13PFL1

AF0409A13PFL1

9:1 Stub Pump

9:1 stub oil pump with 4-1/4" air motor. Pump has 1/2"(F) air inlet, 1-1/2"(F) fluid inlet, and 3/4"(F) fluid outlet. Order *TIM-161* coupler separately to mount pump in tank.

AF0409A53PFL1

9:1 Pump for 55-Gallon Drum

9:1 oil pump with 4-1/4" air motor with built-in check valve for 55-gallon drum. Pump has 1/2"(F) air inlet, 1-1/3"(F) fluid inlet, and 3/4"(F) fluid outlet

OIL PUMP PACKAGES



DM0409A53PFL1000

55-Gallon Drum Pump Package

9:1 oil pump package with 4-1/4" air motor for 55-gallon drum. Includes *AF0409A53PFL1* pump with *TIM-4258-5* 5' air hose, *TIM-4418-8S* 8' material hose and *60870* bung adapter. Pump has 1/2"(F) air inlet, 1-1/2"(F) fluid inlet, and 3/4"(F) fluid outlet.

55-GALLON AIR-OPERATED OIL DISPENSING CARTS



OPTIONS

55-gallon dispensing carts are available with air-operated oil pumps and diaphragm pumps

COST EFFECTIVE

Dispensing carts are a lower cost alternative to installing overhead reels



TIM-730
(drum not included)

MOBILITY

Heavy-duty three-wheel cart allows drums to be moved with ease on any shop's surface (TIM-401)

	Pump	Pump Mounting	Air Coupler	Filter/Regulator	Delivery Hose	Control Handle	Fluid Compatibility
TIM-729	3:1	Drum Mount	Included	P-39224-624	20'	TIM-601-FM	Oil
TIM-729-P	3:1	Drum Mount	Included	P-39224-624	20'	TIM-900B-1	Oil
TIM-730	3:1	Cart Mount	Included	P-39224-624	8'	TIM-601-FM	Oil
NEW TIM-730-5	5:1	Cart Mount	Included	P-39224-624	8'	TIM-601-FM	Oil
TIM-730-P	3:1	Cart Mount	Included	P-39224-624	8'	TIM-900B-1	Oil
TIM-732-AL	1/2" Diaphragm Pump	Cart Mount	Included	P-39224-624	8'	TIM-762	AF & Windshield Washer Fluid
TIM-733	3:1	Drum Mount	Included	P-39224-624	25' Reel	TIM-601-FM	Oil
TIM-733-50	3:1	Drum Mount	Included	P-39224-624	50' Reel	TIM-601-FM	Oil



TIM-729
(drum not included)



TIM-732-AL
(drum not included)



TIM-733
(drum not included)

16-GALLON AIR-OPERATED OIL DISPENSERS

ARO®

OPTIONS

16-gallon air-operated oil dispensers are available with 3:1 or 5:1 pumps, with platform dollies or heavy-duty 3-wheel carts

MOBILITY

The dolly or cart option allows kegs to be moved with ease on any shop's surface



LP2100-1-ALC
(keg not included)

COST EFFECTIVE

Dispensing carts are a lower cost alternative to installing overhead reels

	Pump	Drum Cover	Meter	Control Handle	Material Hose	Platform Dolly	Cart	Fluid Compatibility
LP2100-1-B	3:1	Included	Digital Pint	TIM-762-A	6'	TIM-352	—	Oil
LP2100-1-ALC	3:1	Included	Digital Pint	TIM-762-A	6'	—	TIM-408	Oil
LP3100-1-B	5:1	Included	Digital Pint	TIM-702-A	6'	TIM-352	—	Oil
LP3100-1-ALC	5:1	Included	Digital Pint	TIM-762-A	6'	—	TIM-408	Oil



LP2100-1-B
(keg not included)



LP3100-1-B
(keg not included)



LP3100-1-ALC
(keg not included)

SELF-CONTAINED OIL DISPENSERS

AIR-CHARGED OIL DISPENSER



TIM-390-A1

Heavy-Duty "Pumpless" Metered Oil Dispenser

24-gallon capacity. Ideal for use as a synthetic oil dispenser. The unit must be filled with oil and then charged to 100 PSI. The air hose can then be disconnected and the unit will dispense oil remotely. Dispenses approximately 8 gallons on the first charge and the remaining amount on the second charge. Flow rate approximately 2 gallons per minute. Safety pop-off valve prevents over-pressurization. Includes wide-mouth filling funnel (not shown), air connector, air filter, built-in fluid gauge, 6' discharge hose and a *TIM-601-FM* quart digital metered control valve.

Order 210 air coupler separately

PORTABLE ELECTRIC OIL TRANSFER PUMP WITH FILTER



TIM-307

Electric Oil Filter & Oil Transfer Cart

This filter cart is perfect for transferring oil and for decontaminating oil in bulk storage tanks. The oil is extracted using a 6' suction hose with an integrated inlet screen. The extracted oil is filtered through a 10 micron replaceable cartridge filter and then pumped back through a 6' discharge hose that has a 3' extension tube on the end. Unit has a pressure gauge installed on the filter head which indicates when the filter needs to be replaced. Pump requires 115 VAC and is rated at 8 gallons per minute. Replacement filter number *TIM-307-FIL*.

TIM-307-FIL replacement filter can be sold separately for TIM-307

GEAR OIL DISPENSERS



TIM-60



TIM-61

Container Size	5-Gallon	16-Gallon
Fluid Compatibility	Gear Oil	Gear Oil
Meter	No	No
Accessories	Carrying Handle & Drum Cover	Drum Cover
Hose Length	4'	4'
Nozzle	Goose Neck	Goose Neck

ARO THUNDER 50:1 GREASE PUMPS



RELIABLE DESIGN

Thunder pumps feature a patented, ice-free air motor contained in a rugged housing that is designed to withstand the harshest working environments. ARO is so confident in this design that it is backed by a 5-year warranty

LUBE-FREE AIR MOTOR

Thunder's patented valve design uses no trip rods, push pins, or springs. Instead of one (1) mechanical pilot valve in the air motor, Thunder has two (2) independent 3-way spool valves which work together to change the direction of the pump piston

FEWER PARTS

Thunder pumps are constructed with 50% fewer parts than the majority of comparable pumps. Fewer parts means less problems

GREASE COMPATIBILITY

Thunder pumps are compatible with NLGI 0, NLGI 1, NLGI 2 and NLGI 3 grease

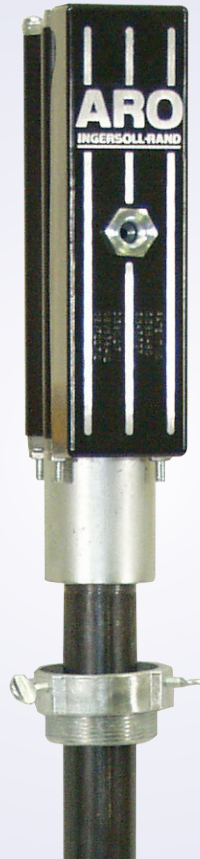

LM2250E-31-B

PROTECTED INLET TUBE

Thunder grease pumps have 5/16" inlet holes in the sides of the bottom of the pick up tube. This helps eliminate problems caused by sucking plastic grease drum liners into the pump's lower section

IN-LINE SERVICE

Thunder grease pump air motors can be serviced in the drum using just a standard wrench

COST-EFFECTIVE DESIGN

Most competitive pumps are too costly to repair after their warranty expires. Thunder's revolutionary design, inexpensive rebuild kits, and field serviceability all add up to a pump that has the lowest cost of ownership in the lubrication equipment market

2" SPECIFICATIONS

Air Inlet	1/4"
Air Inlet Pressure	0 to 150 PSI
Air Motor Diameter	2"
Double-Acting	Yes
Free Flow Rating	9 lbs/Min
Material Outlet	3/8"
Noise Level @ 100 PSI	85 db
Ratio	50:1
Stroke	3"
Working Flow Rating	2 lbs/Min
Rebuild Kit Part Number	637332

3" SPECIFICATIONS

Air Inlet	1/4"
Air Inlet Pressure	0 to 150 PSI
Air Motor Diameter	3"
Double-Acting	Yes
Free Flow Rating	7.45 lbs/Min
Material Outlet	3/8"
Noise Level @ 100 PSI	85 db
Ratio	50:1
Stroke	3"
Working Flow Rating	4 lbs/Min
Rebuild Kit Part Number	637227-B

BARE PUMP MODELS

LM2250E-21-B	2" 50:1 Grease Pump for 35-Pound Container
LM2250E-31-B	2" 50:1 Grease Pump for 120-Pound Container
LM2350E-21-B	3" 50:1 Grease Pump for 35-Pound Container
LM2350E-31-B	3" 50:1 Grease Pump for 120-Pound Container
LM2350E-41-B	3" 50:1 Grease Pump for 400-Pound Container

ARO THUNDER 50:1 GREASE PUMPS STATIONARY PUMP PACKAGES



2" DIAMETER AIR MOTOR

	Size	Bare Pump	Drum Cover	Follower Plate	Material Hose	Air Hose	Z-Swivel	Control Handle
LP2001-1-B	35-lb	LM2250E-21-B	TIM-367-1	TIM-368	—	—	—	—
LP2003-1-B	120-lb	LM2250E-31-B	TIM-451-1	TIM-366	TIM-4516-4	AIR-HP1414-3	—	—
LP2004-1-B	120-lb	LM2250E-31-B	TIM-451-1	TIM-366	TIM-4514-10	—	TIM-111-1	TIM-794

3" DIAMETER AIR MOTOR

	Size	Bare Pump	Drum Cover	Follower Plate	Material Hose	Air Hose	Z-Swivel	Control Handle
LP3002-1	120-lb	LM2350E-31-B	TIM-451-1	TIM-366	TIM-4516-4	AIR-HP1414-3	—	—
LP3005-1	400-lb	LM2350E-41-B	TIM-369	—	TIM-4516-4	AIR-HP1414-3	—	—
LP3008-1	35-lb	LM2350E-21-B	TIM-367-1	TIM-368	TIM-4514-10	—	—	—
LP3009-1	400-lb	LM2350E-41-B	TIM-369	TIM-640015-1	TIM-4516-4	AIR-HP1414-3	—	—

PORTABLE GREASE PUMP PACKAGES

2" DIAMETER AIR MOTOR

	Size	Bare Pump	Drum Cover	Follower Plate	Material Hose	Z-Swivel	Control Handle	Dolly/Cart
LP2002-1-B	35-lb	LM2250E-21-B	TIM-367-1	TIM-368	TIM-4514-10	TIM-111-1	TIM-794	—
LP2006-1-B	120-lb	LM2250E-31-B	TIM-451-1	TIM-366	TIM-4514-10	TIM-111-1	TIM-794	TIM-358
LP2006-1-ALC	120-lb	LM2250E-31-B	TIM-451-1	TIM-366	TIM-4514-10	TIM-111-1	TIM-794	TIM-408

3" DIAMETER AIR MOTOR

	Size	Bare Pump	Drum Cover	Follower Plate	Material Hose	Z-Swivel	Control Handle	Dolly/Cart
LP3001-1	35-lb	LM2350E-21-B	TIM-367-1	TIM-368	TIM-4514-10	TIM-111-1	TIM-794	—
LP3003-1	120-lb	LM2350E-31-B	TIM-451-1	TIM-366	TIM-4514-10	TIM-111-1	TIM-795-1	TIM-358
LP3004-1	120-lb	LM2350E-31-B	TIM-451-1	TIM-366	TIM-4514-10	TIM-111-1	TIM-794	TIM-358
LP3004-1-ALC	120-lb	LM2350E-31-B	TIM-451-1	TIM-366	TIM-4514-10	TIM-111-1	TIM-794	TIM-408
LP3005-1-ALC	400-lb	LM2350E-41-B	TIM-369	TIM-640015-1	TIM-4514-10	TIM-111-1	TIM-794	TIM-401
LP3005-1-50R	400-lb	LM2350E-41-B	TIM-369	TIM-640015-1	50' Reel	TIM-113	TIM-794	TIM-401



LP2002-1-B
(container not included)



LP2004-1-B
(container not included)



LP2006-1-B
(container not included)



LP3005-1-ALC
(container not included)



LP3005-1-50R
(container not included)

ARO AFX GREASE PUMPS



NEW & IMPROVED DESIGN

AFX pumps feature a new innovative and simplistic design with universal parts without sacrificing the reliability of the legacy models

LUBE-FREE AIR MOTOR

AFX Series air motors are self lubricated and do not require an air line lubricator

GREASE COMPATIBILITY

AFX grease pumps are compatible with NLGI 0, NLGI 1, NLGI 2 and NLGI 3 grease



AF0450L43PKL1

HEAVY-DUTY CONSTRUCTION

The AFX Series oil pumps are designed for long distance, heavy viscosity oils, industrial installations and cold weather applications

MUFFLER

AFX Series pumps include a muffler which can also be ported to a remote location for quieter operation



4-1/4" 50:1 SPECIFICATIONS

Air Inlet	1/2"(F)
Air Inlet Pressure	0 to 100 PSI
Air Motor Diameter	4-1/4"
Double-Acting	Yes
Material Outlet	1/2"(F)
Maximum Delivery	6 lbs/Min
Ratio	50:1
Stroke	4"

4-1/4" 50:1 REBUILD KIT

Air Motor Only	637489
Packing Kit	637485

4-1/4" 50:1 ACCESSORIES

Bung Adapter	4148
Drum Cover 120-Pound	66492
Drum Cover 400-Pound	60898
Follower Plate 120-Pound	TIM-363
Follower Plate 400-Pound	TIM-364

4-1/4" 75:1 SPECIFICATIONS

Air Inlet	1/2"(F)
Air Inlet Pressure	0 to 100 PSI
Air Motor Diameter	4-1/4"
Double-Acting	Yes
Material Outlet	1/2"(F)
Maximum Delivery	5.5 lbs/Min
Ratio	75:1
Stroke	6"

4-1/4" 75:1 REBUILD KIT

Air Motor Only	637489
Packing Kit	637512

4-1/4" 75:1 ACCESSORIES

Bung Adapter	4148
Drum Cover 400-Pound	71060-AL
Follower Plate 400-Pound	640015-2

6" 100:1 SPECIFICATIONS

Air Inlet	1/2"(F)
Air Inlet Pressure	0 to 100 PSI
Air Motor Diameter	6"
Double-Acting	Yes
Material Outlet	1/2"(F)
Maximum Delivery	2.1 lbs/Min
Ratio	100:1
Stroke	4"

6" 100:1 REBUILD KIT

Air Motor Service Kit	637489
Packing Kit	65130

6" 100:1 ACCESSORIES

Bung Adapter	4148
Drum Cover 120-Pound	66715
Drum Cover 400-Pound	71060-AL
Follower Plate 120-Pound	640152-1
Follower Plate 400-Pound	640015-5
Integrated Ball Valve Regulator	67442

ARO AFX GREASE PUMPS



BARE PUMP MODELS

4-1/4" DIAMETER AIR MOTOR TYPE

AF0450L43PKL1	4-1/4" 50:1 Grease Pump for 120-Pound Container
AF0450L53PKL1	4-1/4" 50:1 Grease Pump for 400-Pound Container
NEW AF0475L53PBL1	4-1/4" 75:1 Grease Pump for 400-Pound Container

6" DIAMETER AIR MOTOR TYPE

AF060BL43PKL1	6" 100:1 Grease Pump for 120-Pound Container
AF060BL53PKL1	6" 100:1 Grease Pump for 400-Pound Container



AF0450L43PKL1

PUMP PACKAGES

4-1/4" DIAMETER AIR MOTOR

	Size	Bare Pump	Drum Cover	Material Hose	Air Hose	Bung Adapter
DC0450L53PKL1000	400 Pound	AF0450L53PKL1	60898	TIM-4516-5	TIM-4258-5	4148
DM0450L53PKL1000	400 Pound	AF0450L53PKL1		TIM-4516-8	TIM-4258-5	4148

6" DIAMETER AIR MOTOR

	Size	Bare Pump	Drum Cover	Follower Plate	Bung Adapter
DC060BL53PKL1C11	400 Pound	AF060BL53PKL1	71060-AL	640015-5	60870



DC0450L53PKL1000



WARNING

ARO 6" 100:1 pumps deliver pressures up to 10,000 PSI which is in excess of the rated capacity of the accessories shown in this catalog. These 100:1 pumps can only be used in permanently installed systems where the pump is connected directly to piping with a proper rating for the application.

GREASE GUN FILLER PUMP



TIM-80

35-Pound Hand-Operated Grease Gun Filler Pump

Ideal for filling hand grease guns. Includes follower plate, drum cover and loader valve which is compatible with the TIM-23 grease gun loader fitting.

Container not included

35-POUND HAND-OPERATED GREASE PUMP



TIM-83-KM

35-Pound Hand-Operated Grease Pump

Delivers up to 5,000 PSI. Includes drum cover, tapered follower plate, 1/4" x 5' delivery hose, narrow diameter grease coupler and carrying handle. Compatible with NLGI 1 and NLGI 2 grease.

WHEEL BEARING PACKER



TIM-66-A

Drum-Mounted Wheel Bearing Packer with Pump

Mounts directly to 25-pound to 50-pound standard grease containers. Ideal for packing several bearings in a short amount of time. For all car, boat, trailer and RV bearings having an ID of 1/2" to 5", and a height of 1/4" to 2". Rugged steel construction.

Container not included

ARO 1/2" - 2" DIAPHRAGM PUMPS



PATENTED AIR VALVE

ARO's patented "unbalanced" air valve design eliminates stalling, a common occurrence in competitive pumps

RUNS DRY

ARO diaphragm pumps can run dry without any damage to the pump

LUBE-FREE AIR MOTOR

ARO diaphragm pumps are pre-lubricated. They do not require an air lubricator, eliminating maintenance concerns. (The use of a lubricator is not recommended).

VARIETY*

ARO diaphragm pumps are available in metallic and composite bodies, single and multiple-port designs, and many different ball, seat, and diaphragm configurations to suit your application



666100-3C9-C

HI-FLOW

These pumps offer high-volume delivery of material even at low air pressures

BOLTED CONSTRUCTION

Pumps feature bolted construction to avoid the proven problems created by band clamp type pump fasteners

VARIABLE FLOW RATE

Adjusting the air pressure to the pump allows precise control over the pump's flow rate without damaging the pump

SIMPLE DESIGN

Provides trouble-free operation and virtually maintenance-free performer

FLUID COMPATIBILITY



Antifreeze



Automatic Transmission Fluid



Gear Oil



Hydraulic Oil



Motor Oil



Synthetic Oil



Waste Oil



Windshield Washer Fluid

"UNSTALLABLE" AIR VALVE

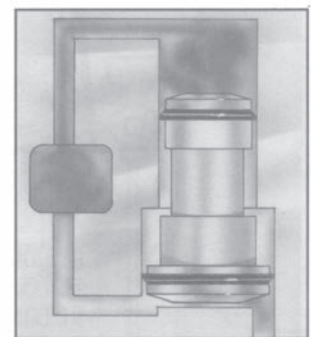
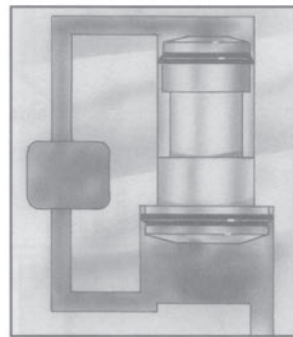

ARO's patented "unbalanced" major air valve has constant air pressure applied to its small end. This assures that the pump resets. Competitive designs lose their signal during every shift, making them vulnerable to stalling. To reverse the valve, air pressure is supplied to the larger end of the valve, allowing the valve to shift — note that constant air pressure continues to be applied to the small end.

* ARO has a complete line of diaphragm pumps to handle most product pumping applications. Please call American Lubrication at 410-252-9300 for recommendations on fluids not listed above.

1/2" DIAPHRAGM PUMPS

	Ball	Diaphragm & O-Ring	Body	Air Inlet (F)	Material Inlet & Outlet (F)	Max PSI	GPM Max
66605J-344*‡	Teflon®	Teflon®	Polypropylene	1/4"	1/2"	100 PSI	13 GPM
NEW 670274-A*	Nitrile	Nitrile	Aluminum	1/4"	1/2"	100 PSI	13 GPM

* Not recommended for oil use in a "closed" system (where the pump remains pressurized when not in use) without thermal relief kit model number PR-100.

‡ Use for antifreeze and windshield washer fluid

1" DIAPHRAGM PUMPS

	Ball	Diaphragm & O-Ring	Body	Air Inlet (F)	Material Inlet & Outlet (F)	Max PSI	GPM Max
666100-344-C*	Teflon®	Teflon®	Aluminum	1/4"	1"	120 PSI	35 GPM
666100-362-C*‡	Acetal	Nitrile	Aluminum	1/4"	1"	120 PSI	35 GPM
666100-3C9-C*	Hytrel®	Hytrel®	Aluminum	1/4"	1"	120 PSI	35 GPM

* Not recommended for oil use in a "closed" system (where the pump remains pressurized when not in use) without thermal relief kit model number PR-100.

‡ Use for antifreeze and windshield washer fluid

1" 50/50 ANTIFREEZE/WATER BLENDING PUMP

	Ball	Diaphragm & O-Ring	Body	Air Inlet (F)	Material Inlet (F)	Material Outlet (F)	Max PSI	GPM Max
650715-C	Acetal	Nitrile	Aluminum	1/4"	1"	1"	120 PSI	35 GPM

1-1/2" DIAPHRAGM PUMP

	Ball	Diaphragm & O-Ring	Body	Air Inlet (F)	Material Inlet & Outlet (F)	Max PSI	GPM Max
666150-362-C	Acetal	Nitrile	Aluminum	1/2"	1-1/2"	120 PSI	90 GPM

2" DIAPHRAGM PUMP

	Ball	Diaphragm & O-Ring	Body	Air Inlet (F)	Material Inlet & Outlet (F)	Max PSI	GPM Max
PD20A-AAP-GGG-B	Nitrile	Nitrile	Aluminum	3/4"	2"	120 PSI	170 GPM



670274-A



666100-3C9-C



PD20A-AAP-GGG-B

ARO DIAPHRAGM DRUM PUMP PACKAGE



MATCHED COMPONENTS

ARO drum pump package components (adapter, siphon tube, etc.) contain pre-specified, matching material of construction for complete fluid compatibility

PATENTED AIR VALVE

ARO's patented "unbalanced" air valve design eliminates stalling, a common occurrence in competitive pumps

SIMPLE DESIGN

Provides trouble-free operation and virtually maintenance-free performance



TIM-734-AL
(Includes filter/regulator with gauge)

RUNS DRY

ARO diaphragm pumps can run dry without any damage to the pump

BOLTED CONSTRUCTION

Pumps feature bolted construction to avoid the proven problems created by band clamp type pump fasteners

LUBE-FREE AIR MOTOR

All ARO 1/2" diaphragm pumps are pre-lubricated. They do not require an air lubricator, eliminating maintenance concerns. (The use of a lubricator is not recommended.)

SPECIFICATIONS

Air Inlet	1/4"(F)
Air Inlet Pressure	100 PSI Maximum
Double-Acting	Yes
Free Flow Rating	13 Gals/Min
Material Outlet	1/2"(F)
Ratio	1:1

	NEW TIM-734-AL*	NEW TIM-734-TAL*
Body	Aluminum	Aluminum
Seat	Polypropylene	Polypropylene
Ball & Diaphragm	Nitrile	Nitrile
Fluid Compatibility	Oil, Water & Antifreeze	Oil, Water & Antifreeze
Container Size	16 to 55-Gallon Drum	275 to 330-Gallon Tote

* Package includes pump, bung adapter, siphon tube, filter/regulator with gauge, weather seal and base. Not recommended for oil use in a "closed" system (where the pump remains pressurized when not in use) without thermal relief kit **PR-100**.

DIAPHRAGM PUMP PACKAGES



55-GALLON ANTIFREEZE PUMP PACKAGES

NEW
612999-1AL

1/2" Wall Mounted Pump Package for Pre-Blended Antifreeze

Includes 670274-A pump, TIM-461-B wall-mount bracket, TIM-1055 siphon tube assembly, two (2) TIM-4418-5 1/2" material hoses, AIR-HP1414-5 air hose, P-39224-624 air filter/regulator/gauge, 210 air coupler, 208 air connector and TIM-212-1 1/2" air adapter

612999-2

1/2" Wall Mounted 50/50 Antifreeze/Water Blending Pump Package

Includes 666053-388 pump, TIM-461-B wall mount bracket, two (2) TIM-1055 siphon tube assemblies, three (3) TIM-4418-5 1/2" material hoses, AIR-HP1414-5 air hose, P-39224-624 air filter/regulator/gauge, 210 air coupler, 2608 air connector and TIM-212-1 1/4" air adapter

612999-3

1" Wall Mounted 50/50 Antifreeze/Water Blending Pump Package

Includes 650715-C pump, TIM-461-B wall mount bracket, two (2) TIM-1058 siphon tube assemblies, two (2) 612999-4H 1" material hoses, TIM-1058 material hose, P-39224-624 air line filter/regulator/gauge, and AIR-HP1414-3 1/4" air hose



612999-3

55-GALLON WINDSHIELD WASHER FLUID PUMP PACKAGES

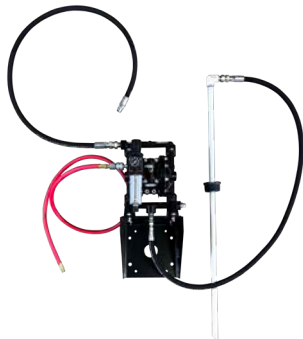

NEW
612999-1AL

1/2" Wall Mounted Pump Package for Windshield Washer Fluid

Includes 670274-A pump, TIM-461-B wall-mount bracket, TIM-1055 siphon tube assembly, two (2) TIM-4418-5 1/2" material hoses, AIR-HP1414-5 air hose, P-39224-624 air filter/regulator/gauge, 210 air coupler, 208 air connector and TIM-212-1 1/2" air adapter

CART-MOUNTED TRANSFER PUMP PACKAGE FOR 55-GALLON DRUMS



NEW
TIM-739

Cart-Mounted Transfer Pump Package for 55-Gallon Drums

Includes heavy-duty three-wheel cart, 1" diaphragm pump, air filter/regulator with gauge, pump mounting bracket, one (1) 1" material coupler/connector sets, 1" x 5' clear suction hose, 1" x 55" long suction pipe and 1" pipe cap

DIAPHRAGM PUMP WASTE OIL PACKAGES

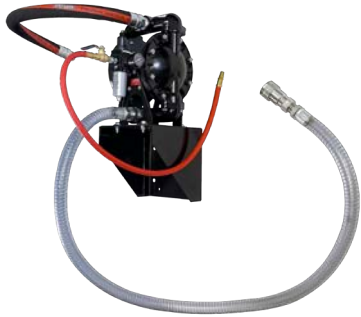

612999-4

Waste Oil Evacuation System

Includes 666100-362-C 1" diaphragm pump, TIM-461-B wall mount bracket, 612999-6H 1" pump inlet hose assembly, 628067-3 1" pump outlet hose assembly, P-39224-624 air line filter/regulator/gauge, AIR-HP1414-3 1/4" air line hose, TIM-180 fluid coupler and TIM-250-BV air valve

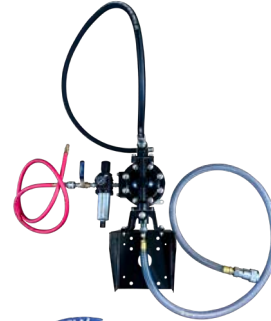

NEW 612999-5AL

1/2" Waste Oil Evacuation System

Includes 670274-A aluminum diaphragm pump, TIM-461-B wall-mount bracket, 612999-5H 3/4" pump inlet hose assembly, TIM-4418-5S 1/2" pump outlet assembly, P-39224-624 air line filter/regulator/gauge, AIR-HP1414-3 1/2" air hose and TIM-180 fluid coupler

DIFFERENTIAL OIL EVACUATION PACKAGE

NEW 612999-6AL



Portable 1/2" Evacuation System

1/2" differential oil evacuation package. Includes 1/2" ported diaphragm pump, tube brackets for hanging the unit from a pit-mounted waste oil drain, 6' fluid suction line, air filter/regulator with gauge and related tubing and fittings

UL FUEL DIAPHRAGM PUMPS

Designed specifically for high-volume transfer, bulk-unloading, or fueling applications. These pumps meet UL 79 specification code and are compatible with gasoline, aviation fuel, diesel fuel, fuel oil, motor oil and kerosene.

To meet UL 79 specifications, pumps utilize pressure relief valves to limit dispensing line pressure to under 50 PSI. If line pressure between the pump and dispensing point exceeds 50 PSI due to thermal expansion, line compression, back pressure or gravity, the relief valve opens and bleeds off excess pressure. The relief valve must be plumbed to return the bleed-off fuel to the storage container.



650717-C

	Ball	Seat	Diaphragm & O-Ring	Body	Air Inlet (F)	Material Inlet & Outlet (F)	Max PSI	GPM Max
650717-C	Acetal	Kynar®	Viton®	Aluminum	1/4"	1"	50 PSI	29 GPM
650718-C	Acetal	Kynar®	Viton®	Aluminum	1/2"	1-1/2"	50 PSI	75 GPM

THUNDER PUMP CONNECTING HOSE KITS



TIM-4430

Connecting Hose Kit for Thunder Oil Pumps

Includes 3' air hose, 4' material hose, air coupler and connector and union adapter

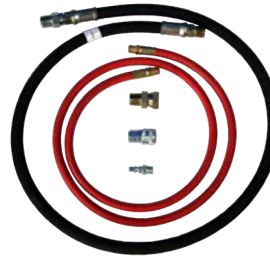

TIM-4431

Connecting Hose Kit for Thunder Oil Pumps

Includes 5' air hose (1/4" NPT (M)), 5' material hose (1/2" NPT (M)), air coupler and connector and union adapter (aka swivel adapter)

PRESSURE RELIEF KITS



PR-100

Relief Setting	100 PSI
Description	Pressure Relief Kit Pressure relief kit used for diaphragm pumps includes relief valve, tee connection, rubber hose and 2" steel adapter for tank. Relief set at 100 PSI.



PR-750

Relief Setting	750 PSI
Description	Pressure Relief Kit Pressure relief kit for 3:1, 5:1 and 9:1 oil pumps includes relief valve, tee connection, rubber hose and 2" steel adapter for tank. Relief set at 750 PSI.

FLUID Y-STRAINERS



TIM-2000-6A

Inlet/Outlet	1/2"(F)
Working Pressure	200 PSI
Description	14 Mesh Filter For keeping contaminants out of a fresh oil system



TIM-2000-10

Inlet/Outlet	1" NPT (F)
Working Pressure	230 PSI
Description	30 Mesh Filter For keeping contaminants out of a waste oil system

STUB PUMP SUCTION TUBES

Suction tubes are made from black steel pipe. The tubes in these charts are based on using no check valve. Subtract 3" from the tube length if using a 3:1 (TIM-196-C) check valve, and subtract 5" from the tube length if using a 5:1 or 9:1 low-level cutoff (TIM-166-LLC). If using a 9:1 Series 425 pump order TIM-161 pipe coupler separately to connect the suction tube to the pump. (Used with bung adapters.)

Tank Used On	For 3:1 Pump 3/4"(M) Pipe	For 5:1 Pump 1-1/2"(M) Pipe	For 9:1 Pump 1-1/2"(M) Pipe
165-Gallon Workbench	TIM-MTL75-25	TIM-MTL-23	TIM-MTL-15
250-Gallon Workbench	TIM-MTL75-25	TIM-MTL-23	TIM-MTL-15
275-Gallon Horizontal Obround	TIM-MTL75-37	TIM-MTL-35	TIM-MTL-26
275-Gallon Vertical Obround	TIM-MTL75-53	TIM-MTL-51	TIM-MTL-42
525-Gallon Horizontal Obround	TIM-MTL75-39	TIM-MTL-37	TIM-MTL-28
500-Gallon Vertical Round	TIM-MTL75-53	TIM-MTL-51	TIM-MTL-42
Cube Style (60" Internal Depth)	TIM-MTL75-53	TIM-MTL-51	TIM-MTL-42



PUMP INLET CHECK VALVES



TIM-166-1



TIM-166-LLC



TIM-196-C

Used On	Thunder 5:1 Pumps	Thunder 5:1 & Series 425 Oil Pumps	Thunder 3:1 Pumps
Description	<p>Inlet Check Valve Installs at the bottom of the pump suction tube to help the pump maintain prime during periods of non-use. 1-1/2"(F) inlet. Check valve is 4-5/8"(L) which must be taken into consideration when ordering the suction tube.</p>	<p>Low-Level Cutoff & Inlet Check Valve Installs at the bottom of the pump suction tube to help the pump maintain prime during periods of non-use. Also helps protect the pump by slowing down the cycle rate if the pump runs dry (no oil in tank). 1-1/2"(F) inlet. Low-level cutoff is 4-5/8"(L) which must be taken into consideration when ordering the suction tube.</p>	<p>Inlet Check Valve Installs at the bottom of the pump suction tube to help the pump maintain prime during periods of non-use. 3/4"(F) inlet. Check valve is 2-3/4"(L) which must be taken into consideration when ordering the suction tube.</p>

BUNG ADAPTERS

	Description	Used On
4148	2"(M) Thread for Use with 1-7/8" Siphon Tube	Series 425 Grease Pumps & AFX Grease Pumps
60870	2"(M) Thread for Use with 2-1/8" Siphon Tube	Series 425 Oil Pumps, Series 600 Grease Pumps & 6" AFX Grease Pumps
67145-2	2"(M) Thread	Thunder Grease Pumps
67145-3-B	2"(M) Thread	Thunder 3:1 Oil Pumps
67145-4-B	2"(M) Thread	Thunder 5:1 Oil Pumps



67145-4-B



67145-3-B

AIR MOTOR MUFFLERS

	Inlet	Size	Used On
93110	3/8"(M)	7/8" x 2-5/8"	1" Diaphragm Pumps
93139	3/4"(M)	3-1/8" x 4-1/4"	1-1/2" Diaphragm Pumps
94117	1-1/2"(M)	2" x 4"	2" & 3" Diaphragm Pumps
96916	1/2"(M)	1" x 3"	AFX Oil & Grease Pumps



93110

MOUNTING BRACKETS

	Description	Used On
61113	Wall-Mount Bracket with 2" Threaded Opening Bracket is slotted to fit over rim of open-head drum	Series 200 Pumps, All Thunder Oil Pumps, Series 425 & AFX Stub Pumps Fitted with Bung Adapters
TIM-460-A	Wall-Mount Bracket with 2" Threaded Opening	All Thunder Oil Pumps
TIM-461-B	Wall-Mount Bracket	1/2" & 1" Diaphragm Pumps
TIM-463	IBC Tote-Bracket for Diaphragm Pumps	1/2" & 1" Diaphragm Pumps
TIM-464-A	IBC Tote-Bracket for Oil Pump & Reel-Mounting	Thunder Oil Pumps, American Lubrication Reels with Two (2) 2" Openings <i>Order 464-INSTL installation kit separately</i>



TIM-460-A



TIM-463



TIM-464-A

MOUNTING BRACKET KITS

	Description	Used On
TIM-460-3	Kit for Wall-Mounting 3:1 Thunder Stub Oil Pumps Includes wall-mount bracket, 3/4" x 6' suction hose, double-tap bushing & adapters <i>Order 3/4" downtube & check valve (TIM-196-C) separately</i>	Thunder 3:1 Stub Pumps
TIM-460-5	Kit for Wall-Mounting 5:1 Thunder Stub Oil Pumps Includes wall-mount bracket, 1" x 8' suction hose, double-tap bushing & adapters <i>Order 1-1/2" downtube & check valve (TIM-166-LLC) separately</i>	Thunder 5:1 Stub Pumps
TIM-465	Tote Mounting & Siphon Kit Includes tote mount bracket, suction hose & oil quick connects	Thunder 3:1 & 5:1 Pumps



TIM-465
(pump not included)

SIPHON TUBES FOR WALL MOUNTED PUMPS

	Container Size	Included Accessories	Tube Material	Foot Valve	Material Outlet Size	Used On
TIM-1049	55-Gallon Drum	1" x 6' Suction Hose	1-1/2" PVC	Yes	1-1/2"(M)	3" or 4-1/4" Stub Oil Pump
TIM-1052	55-Gallon Drum	1" x 6' Suction Hose	1-1/2" PVC	Yes	3/4"(M)	2" Stub Oil Pumps
TIM-1055	55-Gallon Drum	—	1/2" PVC	No	1/2"(F) x 90°	1/2" Diaphragm Pumps Wall-Mounted
TIM-1056	55-Gallon Drum	—	1/2" PVC	No	1/2"(M)	1/2" Diaphragm Pumps Direct Drum-Mount
TIM-1057	275-Gallon Drum	—	1/2" PVC	No	1/2"(M)	1/2" Diaphragm Pumps Direct Tank-Mount
TIM-1058	55-Gallon Drum	—	1-1/2" PVC	Yes	1"(F)	Stub Pumps & 1/2" or 1" Diaphragm Pumps Wall-Mounted
TIM-1059	275-Gallon Tank	—	1-1/2" PVC	Yes	1"(F)	Stub Pumps & 1/2" or 1" Diaphragm Pumps Wall-Mounted
TIM-1059-V	60" Height Tanks	—	1-1/2" PVC	Yes	1"(F)	Stub Pumps & 1/2" or 1" Diaphragm Pumps Wall-Mounted

DRUM COVERS

	Drum Size	# of 2" Threaded Holes	Works with Tie-Down Kits	Used On
TIM-367-1	35-Pound	1	No	Thunder 2" & 3" Grease Pumps
TIM-451-1	16-Gallon/ 120-Pound	1	Yes*	Thunder 2" & 3" Pumps
66492	16-Gallon/ 120-Pound	1	Yes*	AFX Series 4-1/4" Oil & Grease Pumps
66715	120-Pound	1	No	AFX Series 6" Grease Pumps
TIM-369	55-Gallon/ 400-Pound	1	No	Thunder 2" & 3" Pumps
60898	55-Gallon/ 400-Pound	—	No	AFX Series 4-1/4" Grease Pumps
71060-AL	55-Gallon/ 400-Pound	2	Yes*	Thunder Pumps, AFX Series 4-1/4" Grease Pumps Equipped with a Bung Adapter, & AFX Series 6" Grease Pumps

* Tie-down kits not included. Order tie-down kits separately.

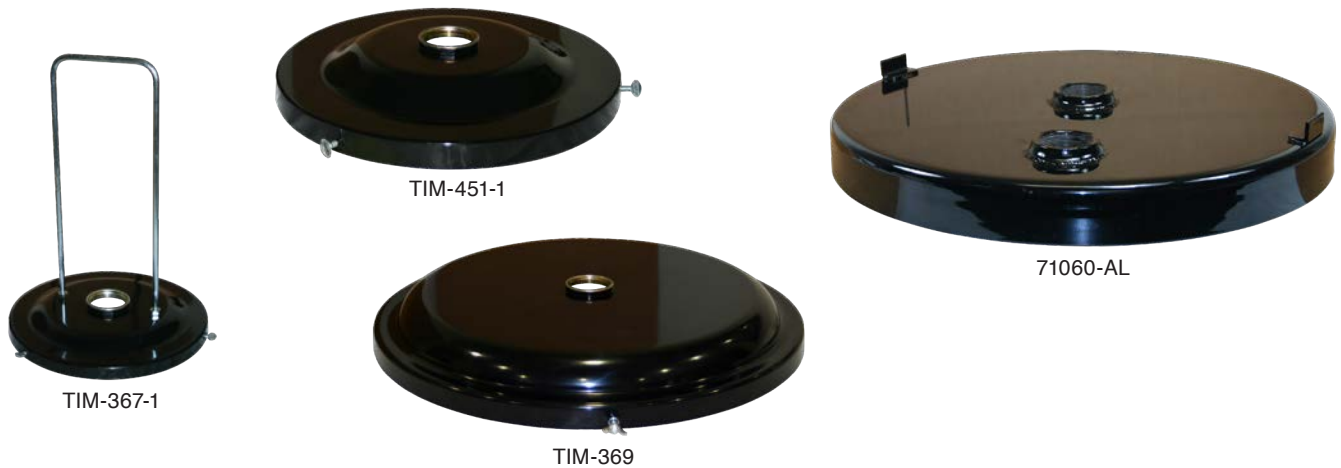

DRUM TIE-DOWN KITS

Tie-down kits facilitate the mounting of drums on lube trucks. Tie-down rods mount to the drum cover and are attached to the truck's floor bed to prevent the drum from moving. Kit includes two (2) tie-down rods and mounting hardware.

	640164	71027-1
Drum Size	16-Gallon, 120-Pound Drum	55-Gallon, 400-Pound Drum
Cover Used With	TIM-451-1	71060-AL
Used On	All Thunder 2" & 3" Pumps	All Thunder 2" & 3" Pumps & All AFX Series Pumps



640164

PUMP LIFTS

ARO



640067

Description	Single-Acting Cylinder Lift for 55-Gallon or 400-Pound Drum
Max Height	92"
Required Drum Cover	71060-AL
Used On	All Thunder 2" & 3" Pumps & All AFX Pumps



640067

GREASE FOLLOWER PLATES

	Drum Size	Wiper Seal Material	Used On
TIM-368	35-Pound	Rubber	Thunder 2" & 3" Grease Pumps
TIM-366	120-Pound	Buna-N	Thunder 2" & 3" Grease Pumps
TIM-363	120-Pound	Buna-N	AFX Series, 50:1 Grease Pumps
640152-1	120-Pound	Buna-N	AFX Series, 100:1 Grease Pumps
TIM-640015-1	400-Pound	Buna-N	Thunder 3" Grease Pumps
640015-2	400-Pound	Buna-N	AFX Series 50:1 & 75:1 Grease Pumps
640015-5	400-Pound	Buna-N	AFX Series 100:1 Grease Pumps
TIM-364	400-Pound	Buna-N	AFX Series 50:1 Thunder Grease Pumps



TIM-368



TIM-363

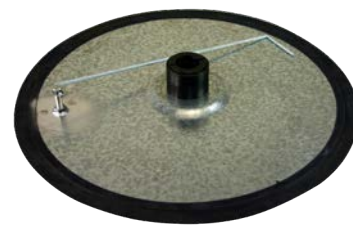

TIM-640015-1

DRUM DOLLIES



TIM-353



TIM-358



TIM-352



TIM-355-1

Drum Size	35-Pound	120-Pound	120-Pound	400-Pound
Used On	Band Dolly with Polypropylene Wheels	Band Dolly with Polypropylene Wheels	Platform Dolly with Polypropylene Wheels	Band Dolly

DRUM CARTS



TIM-401

Heavy-Duty Industrial Drum Cart

For use with either 55-gallon or 400-pound drums. Solid polymer wheels for durability and maneuverability. Equipped with two (2) fixed (8" x 1.5") front wheels and one (1) caster (8" x 1.5") rear wheel with locking brake. The unit includes a drum fastening chain, hose hanger and control handle storage slot. Cart height is 42" from floor to the top of the handle.



TIM-408

3-Wheel Drum Cart

Includes hinged handle, swivel type front wheel and two (2) 6" diameter rubber rear wheels. Accommodates either 16-gallon or 120-pound drum.

Dimensions: 38" L x 22" W x 9" H
Weight: 33 lbs

DRUM ACCESSORIES



TIM-351-8

Drum Cradle with Wheels

This easy to use drum cradle is ideal for storing and moving 55-gallon drums. Includes four (4) 2-1/4" fixed poly wheels and an easy to use lever bar. Weight capacity is 600 pounds.



TIM-351-8HD

Heavy-Duty Drum Cradle with Wheels

This cradle has two (2) 4" fixed wheels in the front and two (2) 4" swivel wheels in the rear for maximum mobility. Has an adjustable handle and weight capacity is 1,100 pounds.



TIM-351-1

Aluminum Drum Wrench

Non-sparking. Opens 3/4" slotted bung and 2" cross bar bung.



TIM-32-34P

Polyethylene Drum Spigot

Self-closing drum spigot fits 3/4" NPT opening. Spigot allows for the use of a lock. Ten (10) pack.



TIM-75



TIM-77



TIM-79-SS

Container Size	16 to 55-Gallon Drums	16 to 55-Gallon Drums	16 to 55-Gallon Drums
Fluid Compatibility	Oils & Non-Corrosive Fluids	Oils & Non-Corrosive Fluids	Antifreeze, Strong Chemicals & Solvents that are Compatible with the Materials Used in the Body & Downtube of the Pump
Downtube Type	Steel Telescoping 18" to 34.5"	Telescoping 18" to 34.5"	Nylon/Stainless Steel
Body Material	Aluminum	Aluminum	Nylon & Stainless Steel with Teflon® Seals. Bung adapter is made of polypropylene.
Pump Type	Lever	Lever	Vertical Pull
Discharge	Twisting Non-Drip Spout	Fixed Spout	Fixed Spout
Delivery	12 Ounces per Stroke	16 Ounces per Stroke	8 Ounces per Stroke



TIM-87



4188

Container Size	5 to 55-Gallon Drums	5 to 55-Gallon Drums
Fluid Compatibility	Antifreeze, Windshield Washer Solvent & Any Product Compatible with Stainless Steel & Teflon®	Various Chemicals, Solvents & Antifreeze
Downtube Type	316 Stainless Steel & Teflon®	Polyethylene
Body Material	316 Stainless Steel & Teflon®	Polyethylene/Polypropylene
Pump Type	Vertical Pull	Siphon
Discharge	Fixed 316 Stainless Steel Spout	7/8" x 8' Hose
Delivery	7 Ounces per Stroke	Siphon

BUTTRESS THREAD ADAPTER



4190

Buttress Thread Adapter

2.5" x 5" buttress. Nylon adapter converts 2" buttress thread to 2" NPT. Ideal for using pumps with 2" NPT male threads on containers which have 2" buttress threads.



TIM-74



TIM-322-A



TIM-323

Container Size	16 to 55-Gallon Drums	16 to 55-Gallon Drums	16 to 55-Gallon Drums
Fluid Compatibility	Oils	Oils & Diesel Fuel	Oils, Gasoline & Diesel Fuel
Downtube Type	Adjustable Bung Adapter	Telescoping 28" to 37"	Telescoping 22" to 40"
Body Material	Cast Iron	Aluminum	Aluminum
Pump Type	Rotary	Lever—pull/push—can be padlocked	Rotary—can be padlocked
Discharge	Spout with 3/4"(M)	5/8" x 7' Delivery Hose (3/4"(M) both ends) & Nozzle	5/8" x 8' Delivery Hose (3/4"(M) both ends) & Nozzle
Delivery	1 Gallon per 12 Revolutions	1 Gallon per 5 Strokes	1 Gallon per 10 Revolutions



4162



4166-1

Container Size	5 to 55-Gallon Drums	5 to 55-Gallon Drums
Fluid Compatibility	Antifreeze, Windshield Washer Fluid, Methanol, Chlorinated Solvents & Some Water-Based Chemicals	DEF, Antifreeze, Windshield Washer Fluid, Methanol, Chlorinated Solvents, & Some Water-Based Chemicals
Downtube Type	Polyethylene	Polyethylene
Body Material	Polyethylene/Polypropylene	Polypropylene with Teflon® Seals
Pump Type	Lever	Rotary
Discharge	Fixed Spout	Fixed Spout
Delivery	13 Ounces per Stroke	8 Ounces per Revolution

ADVANTAGE PLUS SERIES



SLIDE-IN MOUNTING BRACKET

Optional slide-in bracket simplifies reel mounting. Easily allows one person to hand the reel in an overhead application

ENCLOSED SPRING

Cartridge style spring motor is packed with grease and fully enclosed for extra safety. Springs are factory balanced for each size reel

STRENGTH BEADS

Reels are constructed with strength beads for added rigidity

SELF-LUBRICATING

1" double supported steel axle with 1" self-lubricating precision bearings



Compatible

TIM-3628-50

LATCH SPRING

Heavy-duty latch spring is designed for years of trouble-free service, and can be replaced without removing or disassembling the reel

MOUNTING FLEXIBILITY

Multi-position guide arm is easily adjusted for ceiling, floor, wall, tank, or truck mounting

ROLLED EDGES

Hubs are constructed of heavy gauge steel with rolled edges for extra strength and maximum protection

RIGID CONSTRUCTION

Base plate and support post are built from heavy 1/4" plate steel to reduce flexing and fatigue

SIZE INDEX CHART

A	B	C	D	E	Mount L-M
8-7/16"	21-1/2"	20-5/8"	5-3/4"	9"	3-1/2" x 7-1/2"

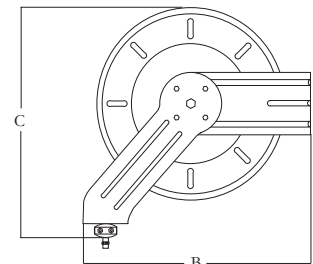
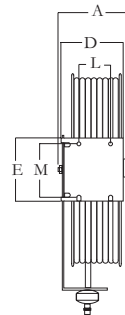

14' maximum mounting height

AIR & WATER REELS - LOW PRESSURE

	For Use On	Hose Size	Max PSI	Delivery Hose	Hose Stop	Inlet/Outlet	Weight
TIM-3616-50A	Air, Water, WWS	3/8" x 50'	300 PSI	TIM-4216-50	TIM-131-3	3/8"(F) / 1/4"(M)	49 lbs.
TIM-3616-65A	Air, Water, WWS	3/8" x 65'	300 PSI	TIM-4216-65	TIM-131-3	3/8"(F) / 1/4"(M)	53 lbs.
TIM-3618-50A	Air, Water, WWS	1/2" x 50'	300 PSI	TIM-4208-50	TIM-131-4	1/2"(F) / 1/2"(M)	60 lbs.
TIM-3618-65A	Air, Water, WWS	1/2" x 65'	300 PSI	TIM-4208-65	TIM-131-4	1/2"(F) / 1/2"(M)	64 lbs.

OIL, ATF & ANTIFREEZE - MEDIUM PRESSURE

	For Use On	Hose Size	Max PSI	Delivery Hose	Hose Stop	Inlet/Outlet	Weight
TIM-3628-25	Oil, ATF, A/F	1/2" x 25'	2,000 PSI	TIM-4418-25S	TIM-131-4	1/2"(F) / 1/2"(M)	47 lbs.
TIM-3628-50	Oil, ATF, A/F	1/2" x 50'	2,000 PSI	TIM-4418-50S	TIM-131-4	1/2"(F) / 1/2"(M)	55 lbs.

GREASE REEL - HIGH PRESSURE

	For Use On	Hose Size	Max PSI	Delivery Hose	Hose Stop	Inlet/Outlet	Weight
TIM-3636-50	Grease	3/8" x 50'	4,000 PSI	TIM-4506-50S	TIM-131-3	3/8"(F) / 3/8"(M)	60 lbs.



TIM-3616-50A



TIM-3628-50



TIM-3636-50

OPTIONAL SLIDE-IN MOUNTING BRACKET



TIM-3600-50

Slide-In Mounting Bracket for Single-Arm Reels

12-3/4" L x 10-1/2" W slide-in mounting bracket simplifies reel mounting by allowing for one man installations. Easily mounts to Uni-Strut® using Uni-Strut® hardware (not included). Can also be mounted by drilling and fastening to an I-Beam or H-Beam (fastening hardware not included). 1/8" steel construction. Mounting hole footprint: 8-13/16" W x 6-3/4" L (1/2" DIA hole).

ADVANTAGE² PLUS SERIES



DUAL ARM DESIGN

Adds rigidity to the reel making it well suited for heavy use, high ceilings or lube truck applications

ENCLOSED SPRING

Cartridge style spring motor is packed with grease and fully enclosed for extra safety

ROLLED EDGES

Hubs are constructed of heavy gauge steel with rolled edges for extra strength and maximum protection

RIGID CONSTRUCTION

Base plate and support post are built from heavy 1/4" plate steel to reduce flexing and fatigue



TIM-3928-50

LATCH SPRING

Heavy-duty latch spring is designed for years of trouble-free service, and can be replaced without removing or disassembling the reel

MOUNTING FLEXIBILITY

Multi-position guide arm is easily adjusted for ceiling, floor, wall, tank, or truck mounting

STRENGTH BEADS

Reels are constructed with strength beads for added rigidity

SELF-LUBRICATING

1" triple supported steel axle with 1" self-lubricating precision bearings

HI-FLOW SWIVEL

Load-free high-flow swivel allows maximum product delivery, and can be replaced without removing or disassembling the reel

SIZE INDEX CHART

A	B	C	D	E	Mount L-M
9"	20-1/2"	23"	7-1/2"	9"	3-1/2" x 7-1/2"

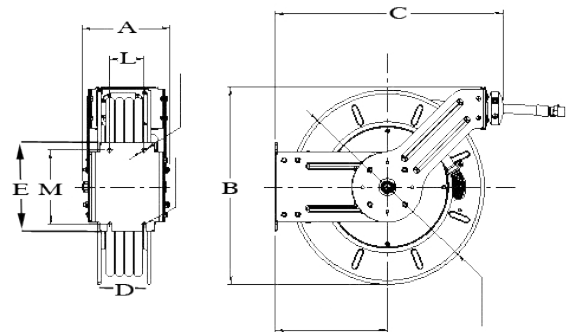

14' maximum mounting height

AIR & WATER REELS - LOW PRESSURE

	For Use On	Hose Size	Max PSI	Delivery Hose	Hose Stop	Inlet/Outlet	Weight
TIM-3916-50A	Air, Water, WWS	3/8" x 50'	300 PSI	TIM-4216-50	TIM-131-3	3/8"(F) / 1/4"(M)	60 lbs.
TIM-3916-65A	Air, Water, WWS	3/8" x 65'	300 PSI	TIM-4216-65	TIM-131-3	3/8"(F) / 1/4"(M)	64 lbs.
TIM-3918-50A	Air, Water, WWS	1/2" x 50'	300 PSI	TIM-4208-50	TIM-131-4	1/2"(F) / 1/2"(M)	71 lbs.
TIM-3918-65A	Air, Water, WWS	1/2" x 65'	300 PSI	TIM-4208-65	TIM-131-4	1/2"(F) / 1/2"(M)	75 lbs.

OIL, ATF & ANTIFREEZE REEL - MEDIUM PRESSURE

	For Use On	Hose Size	Max PSI	Delivery Hose	Hose Stop	Inlet/Outlet	Weight
TIM-3928-50	Oil, ATF, A/F	1/2" x 50'	2,000 PSI	TIM-4418-50S	TIM-131-4	1/2"(F) / 1/2"(M)	68 lbs.

GREASE REEL - HIGH PRESSURE

	For Use On	Hose Size	Max PSI	Delivery Hose	Hose Stop	Inlet/Outlet	Weight
TIM-3936-50	Grease	3/8" x 50'	4,000 PSI	TIM-4506-50S	TIM-131-3	3/8"(F) / 3/8"(M)	83 lbs.



TIM-3916-50A



TIM-3928-50



TIM-3936-50

ADAPTER PLATE



TIM-3900-50

Mounting Plate for Advantage Double-Arm Reels

The *TIM-3900-50* adapter plate makes the Advantage Plus² double-arm reel base compatible with the *TIM-3600-50* slide-in bracket. After the adapter plate is bolted to a double-arm reel base, the reels can be slid into the *TIM-3600-50* bracket.

PLATINUM SERIES PREMIUM DOUBLE-ARM

DUAL ARM DESIGN

Reel is supported on both sides by pedestal style base and arm guides

MOUNTING FLEXIBILITY

Multi-position guide arm is easily adjusted for ceiling, floor, wall, tank or truck mounting

STRENGTH BEADS

Reels are constructed with strength beads for added rigidity

RIGID CONSTRUCTION

Base plate and support post are built from heavy 1/4" plate steel to reduce flexing and fatigue

HI-FLOW SWIVEL

Load-free Hi-Flow swivel allows maximum product delivery. Swivel o-ring seals are supported by Teflon® backup rings for added durability



TIM-3208-75P

ENCLOSED SPRING

Cartridge style spring motor is packed with grease and fully enclosed for extra safety. Springs are factory balanced for each size reel

TRIPLE SUPPORT

Reel axle is independently supported in three (3) separate places and has self-lubricating bearings

ROLLED-EDGE

Hubs are constructed of heavy gauge steel with rolled edges for extra strength and maximum protection

LATCH-OUT PREVENTION

Hose reels can be installed to prevent "latch-out" or locked reel syndrome

DURABLE FINISH

All Platinum Series reels are powder-coated grey for increase durability

SIZE INDEX CHART

Size Index	Reel Dimensions In Inches					Mount L-M
	A	B	C	D	E	
1	9-1/4"	25-1/2"	23"	8"	9"	7" x 8"
2	9-3/4"	25-1/2"	23"	8"	9"	7" x 8"
3	9-7/8"	25-1/2"	24"	8"	9"	7" x 8"
4	12-1/2"	25-1/2"	24"	8"	9"	7" x 8"

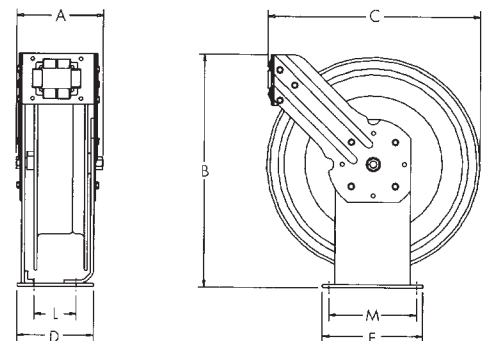

15' maximum mounting height

AIR & WATER REELS - LOW PRESSURE

	Hose Size	Max PSI	Delivery Hose	Hose Stop	Inlet	Delivery Hose Thread Size	Weight	Size Index
TIM-3106-75P	3/8" x 75'	300 PSI	TIM-4216-75	TIM-131-3	3/8"(F)	3/8"(M)	82 lbs.	1
TIM-3106-100P	3/8" x 100'	300 PSI	TIM-4216-100	TIM-131-3	3/8"(M)	3/8"(M)	85 lbs.	1
TIM-3108-75P	1/2" x 75'	300 PSI	TIM-4208-75	TIM-131-4	1/2"(F)	1/2"(M)	82 lbs.	1
TIM-3108-100P	1/2" x 100'	300 PSI	TIM-4208-100	TIM-131-4	1/2"(F)	1/2"(M)	95 lbs.	1

OIL, ATF & ANTIFREEZE REELS - MEDIUM PRESSURE

	Hose Size	Max PSI	Delivery Hose	Hose Stop	Inlet	Delivery Hose Thread Size	Weight	Size Index
TIM-3208-75P	1/2" x 75'	2,500 PSI	TIM-4418-75S	TIM-131-4	1/2"(F)	1/2"(M)	100 lbs.	1
TIM-3208-100P	1/2" x 100'	2,500 PSI	TIM-4418-100S	TIM-131-4	1/2"(F)	1/2"(M)	106 lbs.	1
NEW TIM-3512-50P	3/4" x 50'	1,500 PSI	TIM-4412-50	TIM-430	3/4"(F)	3/4"(M)	94 lbs.	3
NEW TIM-3516-50P	1" x 50'	1,250 PSI	TIM-4416-50	—	1"(F)	1"(M)	116 lbs.	4

GREASE REEL - HIGH PRESSURE

	Hose Size	Max PSI	Delivery Hose	Hose Stop	Inlet	Delivery Hose Thread Size	Weight	Size Index
TIM-3306-75P	3/8" x 75'	4,000 PSI	TIM-4506-75	TIM-131-3	3/8"(F)	3/8"(M)	98 lbs.	2



TIM-3108-75P



TIM-3306-75P



TIM-3512-50P

CABINET ENCLOSURES FOR ADVANTAGE PLUS REELS

CONSTRUCTION

Cabinet enclosures and end panels are constructed of 14-gauge steel

ACCESS PANELS

Removable panels for easy access to the reels

ROLLER GUIDES

Each reel cabinet includes a four-roller non-snag hose guide system that reduces hose wear



DURABLE FINISH

All steel parts are powder-coated with a white textured finish

MOUNTING CHANNEL

Included 1/4" powder-coated mounting plate attaches to 4" to 7-1/2" flange on "I" or "H" beam

CABINET ENCLOSURES & ACCESSORIES

TIM-3600-CAB

Single Cabinet Enclosure

For Advantage Plus Series Reels only. Top, bottom, and back panels are constructed of 14-gauge steel and are painted with a textured white powder-coated finish. Each cabinet includes mounting bracket, non-snag roller outlets and reel access panel. Once the cabinet is mounted the reel slides easily into place. Order one (1) cabinet per reel.

Must remove hose-guide arm from reel before installing

An unlimited number of cabinets can be bolted tight together, side by side

TIM-3600-PAN

End-Panel Kit

Includes two (2) end panels. Design allows for end user to customize the panels with their own logo/decals. Order one (1) kit for each bank of reels.

Decal not included

REQUIRED CONNECTING HOSES FOR CABINET ENCLOSURES

	Fluid Compatibility	Hose ID	Thread Size	Working PSI	Hose Length
AIR-HP3838-4NS	Air	3/8"	3/8"(M) x 1/8"-90° Swivel (M)	300 PSI	4'
TIM-4218-4NS	Air	1/2"	1/2"(M) x 1/2"-90° Swivel (M)	300 PSI	4'
TIM-4418-4NS	Oil	1/2"	1/2"(M) x 1/2"-90° Swivel (M)	2,000 PSI	4'
TIM-4516-4NS	Grease	3/8"	3/8"(M) x 3/8"-90° Swivel (M)	4,000 PSI	4'

THREE-REEL STAND

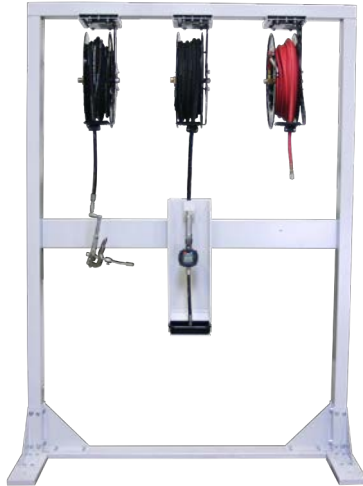

TIM-3000-3

Hose Reel Stand for Up to 3 Hose Reels

Reel stand is painted gray. Optional *TIM-466* drip trays can be installed on the stand.

Dimensions: 70" length x 40" width x 93" height

DRIP TRAY



TIM-466

Drip Tray for Control Handles

Drip tray can be mounted on the *TIM-3000-3* or on a wall

Dimensions: 9" length x 6.5" width x 27-3/4" height

HOSE REEL CONNECTING HOSES

	Fluid Compatibility	Hose ID	Thread Size	Working PSI	Hose Length
AIR-HP3838-2	Air	3/8"	3/8"(M) x 3/8"(M)	300 PSI	2'
AIR-HP3838-2NS	Air	3/8"	3/8"(M) x 3/8"-90° Swivel (M)	300 PSI	2'
AIR-HP3838-4NS	Air	3/8"	3/8"(M) x 3/8"-90° Swivel (M)	300 PSI	4'
TIM-4218-2NS	Air	1/2"	1/2"(M) x 1/2"-90° Swivel (M)	300 PSI	2'
TIM-4218-4NS	Air	1/2"	1/2"(M) x 1/2"-90° Swivel (M)	300 PSI	4'
TIM-4418-2NS	Oil	1/2"	1/2"(M) x 1/2"-90° Swivel (M)	2,000 PSI	4'
TIM-4418-4NS	Oil	1/2"	1/2"(M) x 1/2"-90° Swivel (M)	2,000 PSI	4'
TIM-4412-3	Grease	3/4"	3/4"(M) x 3/4"(M)	1,250 PSI	3'
TIM-4412-5	Oil	3/4"	3/4"(M) x 3/4"(M)	1,250 PSI	5'
TIM-4516-2NS	Grease	3/8"	3/8"(M) x 3/8"-90° Swivel (M)	4,000 PSI	2'
TIM-4516-4NS	Grease	3/8"	3/8"(M) x 3/8"-90° Swivel (M)	4,000 PSI	4'

HOSE STOPS

	Hose ID	Outside Diameter	Reel	Style
TIM-254-D	1/2"	3-1/2"	Quick Lube Consoles	Donut
TIM-131-A	1/4"	2-1/2"	All 1/4" ID Hose Reels	Donut
TIM-131-3	3/8"	3"	3/8" Air Reels	Donut
TIM-131-4	1/2"	3"	1/2" Oil & Air Reels	Donut
TIM-430	3/4"	3-1/2"	3/4" Oil Reels	Donut

PRO SERIES DIGITAL CONTROL VALVES

EXCLUSIVE DESIGN

This meter is built exclusively for American Lubrication Equipment Corporation, incorporating numerous design ideas provided by their design team

SUPERIOR DESIGN

Fluid is completely separated from the electronic head. The entire electronics head/puck is available as a replacement part

BATTERIES

New AAA battery design lasts up to 3 times longer

MODULAR ASSEMBLY

Swivel, control valve, meter and tip assembly are separate units which simplifies repair

TRIGGER GUARD & LOCK

All Trigger Guard (TG) style control valves have a built-in trigger guard which helps prevent accidental dispensing as well as a built-in trigger lock for hands-free dispensing



TIM-601-FM

FIELD REPAIRABLE

This design enables the user to replace the circuit board while the meter is installed under pressure

PROGRAMMABLE

All Pro Series digital meters are programmable to pints, quarts, liters and gallons

SHOCK-RESISTANT

Rugged shock-resistant design stands up to the harshest environment. Meter covers have a molded-in soft rubber shock-guard for added protection

FILTER

All Pro Series digital control valves have built-in filters for added protection

3-YEAR LIMITED WARRANTY

All Pro Series digital control valves come with a 3-year limited warranty

SPECIFICATION

Accuracy	± .5%
Flow Range (TIM-615)	1 to 26 Qts/Min
Inlet/Outlet	1/2" NPT (F)
Measurement	Pints, Quarts, Liters, Gallons
Meter Mechanism	Oval Gear
Operating Pressure	1,000 PSI
Operating Temperature	23° to 140°F
Repeatability	± .3%
Storage Temperature	-5° to 158°F
Weight (TIM-600-FM)	2.8 lbs

TIM-615 COMPONENT VIEW



FLUID COMPATIBILITY

Automatic Transmission Fluid	Gear Oil	Hydraulic Oil
Motor Oil	Synthetic Oil	

DIGITAL PRO SERIES TG STYLE CONTROL VALVE

	Metered Units	Totalizer Units	Tip Assembly	Tip Assembly Description	Tip Diameter	Working Flow Rate
TIM-600-FA	Pts/Qts/Lts/Gals	Lts/Gals	TIM-747	Flex Automatic	1/2"	2.5 GPM
TIM-600-FM	Pts/Qts/Lts/Gals	Lts/Gals	TIM-743	Flex Manual	5/8"	2.5 GPM
TIM-600-FMHF	Pts/Qts/Lts/Gals	Lts/Gals	TIM-743-1	Flex Manual Hi-Flow	15/16"	4 GPM
TIM-600-RA	Pts/Qts/Lts/Gals	Lts/Gals	TIM-746	Rigid Automatic	1/2"	2.5 GPM
TIM-600-RM	Pts/Qts/Lts/Gals	Lts/Gals	TIM-753	Rigid Manual	1/2"	2.5 GPM
TIM-600-RMGO	Pts/Qts/Lts/Gals	Lts/Gals	TIM-742	90° Rigid Manual	1/2"	2.5 GPM
TIM-600-RMHF	Pts/Qts/Lts/Gals	Lts/Gals	TIM-752	Rigid Manual Hi-Flow	15/16"	4 GPM

Order optional colored swivel guards separately. See page 51.



TIM-600-RM

DIGITAL PRO SERIES STANDARD CONTROL VALVES

	Metered Units	Totalizer Units	Tip Assembly	Tip Assembly Description	Tip Diameter	Working Flow Rate
TIM-601-FA	Pts/Qts/Lts/Gals	Lts/Gals	TIM-747	Flex Automatic	1/2"	2.5 GPM
TIM-601-FM	Pts/Qts/Lts/Gals	Lts/Gals	TIM-743	Flex Manual	5/8"	2.5 GPM
TIM-601-FMHF	Pts/Qts/Lts/Gals	Lts/Gals	TIM-743-1	Flex Manual Hi-Flow	15/16"	4 GPM
TIM-601-RA	Pts/Qts/Lts/Gals	Lts/Gals	TIM-746	Rigid Automatic	1/2"	2.5 GPM
TIM-601-RM	Pts/Qts/Lts/Gals	Lts/Gals	TIM-753	Rigid Manual	1/2"	2.5 GPM
TIM-601-RMGO	Pts/Qts/Lts/Gals	Lts/Gals	TIM-742	90° Rigid Manual	1/2"	2.5 GPM
TIM-601-RMHF	Pts/Qts/Lts/Gals	Lts/Gals	TIM-752	Rigid Manual Hi-Flow	15/16"	4 GPM

Order optional colored swivel guards separately. See page 51.



TIM-601-FM

TIP EXTENSIONS



TIM-742



TIM-743



TIM-743-1



TIM-746



TIM-747



TIM-752



TIM-753

PRO SERIES MECHANICAL CONTROL VALVES

SUPERIOR DESIGN

Enables the use of manual non-drip tips

MODULAR ASSEMBLY

Swivel, control valve, meter and tip assembly are separate units which simplifies repair

SHOCK-RESISTANT

Rugged shock-resistant design stands up to the harshest environments. Meter bodies are equipped with a soft rubber shock-guard for added protection

TRIGGER GUARD

All Trigger Guard (TG) style control valves have a built-in trigger guard which helps prevent accidental dispensing

3-YEAR LIMITED WARRANTY

All Pro Series mechanical control valves come with a 3-year limited warranty



TIM-650-FM

DURABLE

No exposed pointers to break or turn backwards

SELF-POWERED

Eliminates the headaches associated with dead batteries

FILTER

All Pro Series mechanical control valves have built-in filters for added protection

TRIGGER LOCK

All TG style control valves have a built-in trigger lock, allowing hands-free operation

SPECIFICATIONS

Accuracy	± 1%
Flow Range (TIM-615)	0.25 to 8 Gals/Min
Inlet/Outlet	1/2" NPT (F)
Measurement	Quarts
Meter Mechanism	Oval Gear/Mechanical
Operating Pressure	1,000 PSI
Operating Temperature	-4° to 176°F
Repeatability	± .2%
Storage Temperature	-4° to 176°F
Weight (TIM-650-FM)	3.45 lbs

FLUID COMPATIBILITY



Automatic
Transmission Fluid



Gear Oil



Hydraulic Oil



Motor Oil



Synthetic Oil

MECHANICAL PRO SERIES TG STYLE CONTROL VALVES

	Metered Units	Totalizer Units	Tip Assembly	Tip Assembly Description	Tip Diameter	Working Flow Rate
TIM-650-FA	Quarts	Quarts	TIM-747	Flex Automatic	1/2"	2.5 GPM
TIM-650-FM	Quarts	Quarts	TIM-743	Flex Manual	5/8"	2.5 GPM
TIM-650-FMHF	Quarts	Quarts	TIM-743-1	Flex Manual Hi-Flow	15/16"	4 GPM
TIM-650-RA	Quarts	Quarts	TIM-746	Rigid Automatic	1/2"	2.5 GPM
TIM-650-RM	Quarts	Quarts	TIM-753	Rigid Manual	1/2"	2.5 GPM
TIM-650-RMHF	Quarts	Quarts	TIM-752	Rigid Manual Hi-Flow	15/16"	4 GPM

Order optional colored swivel guards separately. See page 51.



TIM-650-RM

MECHANICAL PRO SERIES STANDARD CONTROL VALVES

	Metered Units	Totalizer Units	Tip Assembly	Tip Assembly Description	Tip Diameter	Working Flow Rate
TIM-651-FA	Quarts	Quarts	TIM-747	Flex Automatic	1/2"	2.5 GPM
TIM-651-FM	Quarts	Quarts	TIM-743	Flex Manual	5/8"	2.5 GPM
TIM-651-FMHF	Quarts	Quarts	TIM-743-1	Flex Manual Hi-Flow	15/16"	4 GPM
TIM-651-RA	Quarts	Quarts	TIM-746	Rigid Automatic	1/2"	2.5 GPM
TIM-651-RM	Quarts	Quarts	TIM-753	Rigid Manual	1/2"	2.5 GPM
TIM-651-RMHF	Quarts	Quarts	TIM-752	Rigid Manual Hi-Flow	15/16"	4 GPM

Order optional colored swivel guards separately. See page 51.



TIM-651-FM

TIP EXTENSIONS



TIM-743



TIM-743-1



TIM-746



TIM-747



TIM-752



TIM-753

900 SERIES DIGITAL PRESET METERS

ERGONOMIC

900 Series meters are designed with a anatomical hand grip and a trigger that requires minimal pressure to operate

PROGRAMMABLE

User can store five (5) programmable preset values in the meter's memory that can be easily recalled at the time of dispense. The meter always stores the amount of the previous dispense as a sixth preset value

TRIGGER GUARD

Preset meters have a built-in trigger guard which helps prevent accidental dispensing

LED DISPLAY

Large, easy to read LED display shows the dispensing amount and totalizer value at the same time

FILTER

All 900 Series digital control valves have built-in filters for added protection



TIM-900B-1

SWIVEL EXTENSION

All digital preset meters are equipped with a patented multi-position extension that threads directly into the meters body. Units with a rigid extension are also equipped with a rotatable non-drip tip

VERSATILE

Digital preset meters can be set up to measure in pints, quarts, liters or gallons

SWIVEL GUARD

Units are equipped with a black swivel guard which prevents the swivel from damaging the vehicle's finish which being serviced

BATTERIES

Meters use four (4) standard AA batteries which are field replaceable. The meter's memory is retained even during power loss

SPECIFICATIONS

Accuracy	± .5%
Flow Range	0.26 to 7.9 Gals/Min
Inlet Size	1/2"(F)
Measurements	Pints, Quarts, Liters, Gallons
Meter Mechanism	Oval Gear
Operating Pressure	1,000 PSI Max
Operating Temperature	23° to 122°F
Power	Four (4) 1.5-volt AA Batteries
Repeatability	± .2%
Storage Temperature	-31° to 140°F
Weight	3 lbs

FLUID COMPATIBILITY



Automatic
Transmission Fluid



Gear Oil



Hydraulic Oil



Motor Oil



Synthetic Oil

900 SERIES DIGITAL PRESET METERS



	TIM-900B-1	TIM-901B-1	TIM-901B-HF
Unit of Measure	Pts/Qts/Lts/Gals	Pts/Qts/Lts/Gals	Pts/Qts/Lts/Gals
Tip Extension	TIM-758-1	TIM-756-1	TIM-755-1
Tip Extension Description	Rigid Automatic	Flex Automatic	Flex Manual Hi-Flow
Tip Diameter	1/2"	1/2"	15/16"
Working Flow Rate	2.5 GPM	2.5 GPM	4 GPM

All 900 Series meters include a black swivel guard. For other color swivel guards see page 51.

TIP EXTENSIONS



Tips are NOT backward compatible with black TIM-900-1 and grey TIM-900A-1 handles

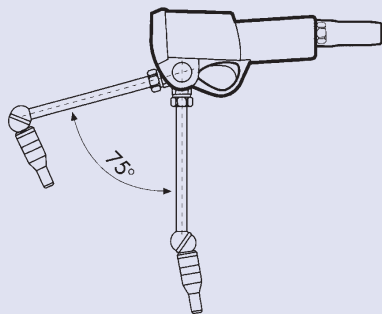

All TIM-900 Series digital preset meters have a swiveling extension. Units equipped with rigid extensions also have a rotatable automatic non-drip tip.

MECHANICAL PRESET METERS

BALANCED DESIGN

Preset mechanical meters have a light-weight, balanced design for ease of use

TRIGGER GUARD

Built-in trigger guard which helps prevent accidental dispensing

INLET SWIVEL

1/2" (F) swivel comes standard on all mechanical style meters



TIM-911-HF

IMPACT RESISTANT

An impact resistant nylon shroud protects the meter's knob and register dial

MANUAL TIPS

Units come equipped with manual Hi-Flow non-drip tips

SPECIFICATIONS

Accuracy — Mechanical	± .65%
Accuracy — Preset	± 3%
Flow Range	0.4 to 3.0 Gals/Min
Inlet Size	1/2"(F)
Operating Pressure	1,000 PSI Max
Operating Temperature	45° to 110°F
Weight	4 lbs

FLUID COMPATIBILITY



Automatic Transmission Fluid



Gear Oil



Hydraulic Oil



Motor Oil



Synthetic Oil



Antifreeze

	Metered Units	Totalizer Units	Tip Assembly	Description	Tip Diameter	Working Flow
TIM-910-HF	16 Quarts	Quarts	TIM-743-RHF	Rigid Manual Hi-Flow	15/16"	3 GPM
TIM-911-HF	60 Gallons	Gallons	TIM-743-RHF	Rigid Manual Hi-Flow	15/16"	3 GPM
TIM-912-HF	60 Gallons	Gallons	TIM-743-RHF	Rigid Manual Hi-Flow	15/16"	3 GPM

1/2" IN-LINE METERS



TIM-615



TIM-616

Type	Digital	Mechanical
Inlet/Outlet	1/2" NPT (F)	1/2" NPT (F)
Fluid Compatibility	Lubricants & Antifreeze	Lubricants & Antifreeze
Metered Units	Pts/Qts/Lts/Gals	Quarts
Totalizer Units	Liters/Gallons	Quarts
Working Flow Rate	1 to 32 Qts/Min	1 to 32 Qts/Min
Maximum PSI	1,000 PSI	1,000 PSI

3/4" - 1-1/2" IN-LINE DIGITAL METERS

In-line fluid meters allow for easy monitoring of fluid dispensing. The following digital electronic meters include two (2) 1.5V "N" style batteries (AAA batteries). Accuracy within the flow range is $\pm .5\%$, and repeatability is $\pm .2\%$.



TIM-717-1



TIM-717-2



TIM-717-3

Inlet/Outlet	3/4"(F)	1"(F)	1-1/2"(F)
Fluid Compatibility	Lubricating Oils, Diesel Fuel & Antifreeze Mixtures	Lubricating Oils, Diesel Fuel & Antifreeze Mixtures	Lubricating Oils, Diesel Fuel & Antifreeze Mixtures
Metered Units	Pts/Qts/Lts/Gals	Pts/Qts/Lts/Gals	Pts/Qts/Lts/Gals
Totalizer Units	Gallons	Gallons	Gallons
Working Flow Rate	1.3 to 13 Gals/Min	2.6 to 26 Gals/Min	4 to 40 Gals/Min
Maximum PSI	1,000 PSI	435 PSI	290 PSI

760 SERIES NON-METERED CONTROL VALVES

MORE CHOICES

760 Series control valves come in a wide variety of configurations. Two (2) valve style and seven (7) different tips allow you to choose the valve that best fits your application

IMPACT RESISTANT

Rugged impact-resistant design stands up to the harshest environments

TRIGGER GUARD

All Trigger Guard (TG) style valves have a built-in trigger guard which helps prevent accidental dispensing

NON-DRIP TIPS

Valves are available in both manual and automatic non-drip tip configurations



TIM-762

LIGHT WEIGHT

Control valves are made of aluminum creating a lightweight, perfectly-balanced design

FILTER

All 760 Series control valves have built-in filters for added protection

TRIGGER LOCK

All TG style valves have a built-in trigger lock, allowing hands-free operation

SPECIFICATIONS

Flow Range	0.4 to 4.0 Gals/Min
Inlet Size	1/2"(F)
Operating Pressure	1,000 PSI
Weight (TIM-761)	1.9 lbs
Weight (TIM-761-TG)	1.6 lbs

FLUID COMPATIBILITY



Automatic Transmission Fluid



Gear Oil



Hydraulic Oil



Motor Oil



Synthetic Oil

TG STYLE NON-METERED CONTROL VALVES

	Description	Tip Extension	Tip Diameter	Working Flow Rate
TIM-761-TG	Rigid Automatic	TIM-746	1/2"	2.5 GPM
TIM-761-TGM	Rigid Manual	TIM-753	1/2"	2.5 GPM
TIM-761-TGHF	Rigid Hi-Flow Manual	TIM-752	15/16"	4 GPM
TIM-761-TGGO	90° Rigid Manual	TIM-742	1/2"	2.5 GPM
TIM-762-TG	Flex Manual	TIM-743	5/8"	2.5 GPM
TIM-762-TGA	Flex Automatic	TIM-747	1/2"	2.5 GPM
TIM-762-TGHF	Flex Hi-Flow Manual	TIM-743-1	15/16"	4 GPM

Order optional colored swivel guards separately. See page 51.



TIM-762-TG

STANDARD NON-METERED CONTROL VALVES

	Description	Tip Extension	Tip Diameter	Working Flow Rate
TIM-761	Rigid Automatic	TIM-746	1/2"	2.5 GPM
TIM-761-M	Rigid Manual	TIM-753	1/2"	2.5 GPM
TIM-761-HF	Rigid Hi-Flow Manual	TIM-752	15/16"	4 GPM
TIM-761-GO	90° Rigid Manual	TIM-742	1/2"	2.5 GPM
TIM-762	Flex Manual	TIM-743	5/8"	2.5 GPM
TIM-762-A	Flex Automatic	TIM-747	1/2"	2.5 GPM
TIM-762-HF	Flex Hi-Flow Manual	TIM-743-1	15/16"	4 GPM

Order optional colored swivel guards separately. See page 51.



TIM-761-M

TIP EXTENSIONS



TIM-742



TIM-743



TIM-743-1



TIM-746



TIM-747



TIM-752



TIM-753

ARO NON-METERED CONTROL VALVES



FILTER

All ARO non-metered control valves have built-in filters for added protection

SWIVEL

Standard control valves include 1/2" swivel. Order swivels for Hi-Flow versions separately



TRIGGER LOCK

Valves have a built-in trigger lock, allowing hands-free operation







5-YEAR WARRANTY

All ARO standard and Hi-Flow non-metered control valves come with a 5-year warranty

SPECIFICATIONS

Flow Range (Hi-Flow)	0.4 to 10 Gals/Min
Flow Range (Standard)	0.4 to 3 Gals/Min
Inlet Size (Hi-Flow)	3/4" NPT (F)
Inlet Size (Standard)	1/2" NPT (F)
Weight (635193)	3.2 lbs
Weight (635392)	2.2 lbs

FLUID COMPATIBILITY

 Antifreeze Mixtures	 Automatic Transmission Fluid	 Gear Oil
 Hydraulic Oil	 Motor Oil	 Synthetic Oil

NON-METERED VALVES

	635392	635193
Type	Standard	Hi-Flow
Used On	3:1, 5:1 & 9:1 Pumps	1:1, 3:1 & 5:1 Pumps
Description	Flexible Manual Non-Drip	Flexible Manual Non-Drip
Inlet	1/2"(F)	3/4"(F)
Tip Diameter	1/2"	1-1/8"
Max PSI	1,000 PSI	600 PSI

HI-FLOW SWIVEL

635108

Fluid Compatibility	Engine Oils & Antifreeze
Description	For Use on ARO Hi-Flow Non-Metered Valves
Inlet/Outlet	3/4"(M) x 3/4"(F)
Max PSI	1,000 PSI



635108

HI-FLOW/MEDIUM PRESSURE OIL NOZZLE

TIM-48

Fluid Compatibility	Fluid Lubricants
Inlet	3/4" Swivel (F)
Shut Off Style	Semi-Automatic
Working Flow Rate	21 GPM
Max PSI	1,470 PSI



TIM-48

WATER & ANTIFREEZE BIBBS

Low volume dispensing valves for water or antifreeze

TIM-94-MI

Spout	Neoprene
Pressure Rating	35 PSI
Inlet	1/4"(F) NPT



TIM-94-MI

SWIVEL GUARDS

Ideal for color coding products. Swivel guard helps protect cars from damage. Can be used on any ARO or American Lubrication oil control valve with a 1/2" swivel inlet.



TIM-720-BLK



TIM-720-BLU



TIM-720-GRN



TIM-720-RED



TIM-720-YEL

Color	Black	Blue	Green	Red	Yellow
-------	-------	------	-------	-----	--------



STANDARD, BOOSTER & HI-FLOW CONTROL VALVES



TIM-794

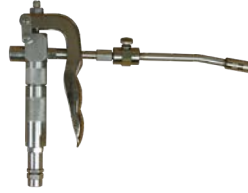

TIM-795-1



636111

Inlet/Outlet	1/4"(F)	1/4"(F)	1/8"(M) & 3/8"(F)
Max Inlet PSI	7,500 PSI	7,500 PSI	7,500 PSI
Description	<p>Heavy-Duty Grease Control Valve Includes whip hose and coupler</p>	<p>Heavy-Duty Booster Control Valve Built-in trigger booster feature delivers up to 7,500 PSI to break loose tough fittings. Includes manual pressure vent for easy disconnect. Do not use with whip hose.</p>	<p>ARO Heavy-Duty Grease Control Valve Standard high-pressure grease control handle with inlet filter. Shipped with adapter to allow either 1/8"(M) or 3/8"(F) inlet. Maximum working 7,500 PSI.</p>

GREASE SWIVELS & ACCESSORIES

	Type	Thread Size	Max PSI	Used On
TIM-111-1	Z-Swivel	1/4"(M) x 1/4"(F)	6,000 PSI	Existing Balcrank, Graco & American Lube Grease Systems
TIM-113	Z-Swivel	3/8"(F) x 1/4"(M)	6,000 PSI	3/8" ID Grease Hoses
TIM-115	Z-Swivel	1/8"(F) x 3/8"(F)	6,000 PSI	3/8" ID Grease Systems
TIM-116	Z-Swivel	1/8"(M) x 1/8"(F)	6,000 PSI	1/4" ID Grease Hoses
636088	Z-Swivel	3/8"(M) x 3/8"(F)	8,000 PSI	3/8" ID High-Volume Grease Systems
636075	Straight	1/8"(M) x 1/8"(F)	8,000 PSI	Grease Systems
636085	Straight	3/8"(M) x 3/8"(F)	8,000 PSI	Grease Systems

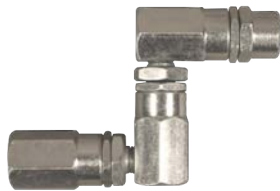

TIM-115



636088



636085

GREASE GUN COUPLERS



TIM-100

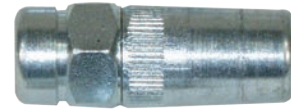

TIM-101

Body	Narrow Diameter	Standard Diameter
Thread Size	1/8"(F)	1/8"(F)
Ball Check	Yes	Yes
Max PSI	10,000 PSI	10,000 PSI

GREASE WHIP HOSES

High pressure grease whip hoses can be connected to the outlet side of the rigid extension of a grease control valve to allow the service technician to access hard-to-reach fittings. These hose assemblies are constructed of two-wire braid hose and high pressure couplings giving them a working pressure of 5,000 PSI.

Do not use whip hoses with booster control valve (*TIM-795-1*)



TIM-4360



TIM-4361

Thread Size	1/8"(M) x 1/8"(M)	1/8"(M) x 1/8"(M)
Hose Length	12"	18"
Connection Info	Order <i>TIM-1230</i> adapter to connect to grease gun extension	Order <i>TIM-1230</i> adapter to connect to grease gun extension

OIL BARS

Used as a dispensing option to reels, usually in conjunction with 5-quart measuring containers. Dispensing assembly now includes a custom splash-reduction adapter. Holes are pre-drilled in sides to facilitate the mounting of ready lights for use with fluid inventory control system. Available in single-, double- or triple-spigot configurations. Units feature black powder-coated finish, non-drip spigots, flanged back for easy mounting, drip pan with bright zinc-plated grid and drain port. Shipped complete with mounting bracket and 30" connecting hose with 90° union adapter for easy connection to fluid line. All oil bars have the same dimensions: 23" H x 22" W x 15" D (above the drip pan). Metered units are equipped with *TIM-615* digital quart meter.



TIM-2-A

SPIGOT REPAIR KIT

TIM-OILSPIGOT-KIT

Spigot Repair Kit
TIM-5-A2 oil bar and
TIM-724-1B taper spigot repair kit. Kit includes: O-rings, black steel roll pin, outlet gasket/seal.

	TIM-1-A	TIM-1A-DM	TIM-2-A	TIM-2A-DM	TIM-3-A	TIM-3A-DM
Number of Spigots	1	1	2	2	3	3
Metered or Non-Metered	Non-Metered	Metered	Non-Metered	Metered	Non-Metered	Metered



TIM-1-A



TIM-2A-DM



TIM-3-A

OIL BAR ACCESSORIES

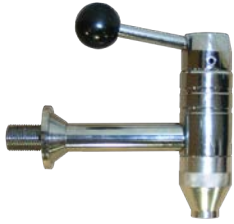

TIM-5-A2

Replacement Oil Bar Spigot

1/2" NPT (M) threads. 1,015 PSI (70 bar) pressure rating. Compatible with oil and hydraulic oil. Includes product manual, spigot retaining nut and flat washer.



TIM-6

Oil Bar Adapter Kit

Used to connect fluid dispensing system solenoid valve to oil bar. Use one (1) kit per outlet.



TIM-500-FV

Flow Control Valve

Used in the material line that supplies the oil bar to control and adjust the delivery rate and prevent splashing

MEASURING CONTAINERS & ACCESSORIES



TIM-30-5A

6-Pack of 5-Quart Graduated Measuring Containers

Units include an easy-open hinged lid to help protect from contaminants. Color is transparent white for easy viewing of liquid level. Box contains six (6) units.



TIM-30-11A

Plastic Replacement Spout

For *TIM-30-5A*

BIG ALEC V

TOUCHSCREEN DESIGN

State of the art touchscreen eliminates dated keypad design

EASY TO OPERATE

Touchscreen display prompts the user with operating instructions

TWO PRODUCT CAPABILITY

The 2003-P2 can dispense two (2) products to 12 stations (6 stations per product)

EXTREMELY ACCURATE

Field calibrateable for the highest level of accuracy

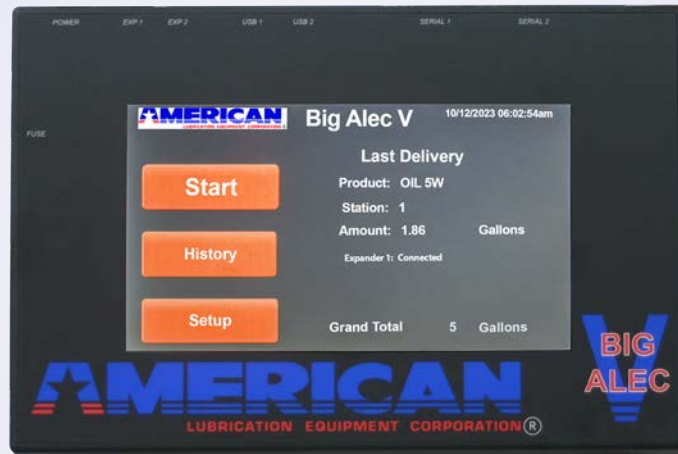

CHANGEABLE UNIT OF MEASURE

Can be programmed in the field for pints, quarts, gallons or liters

PRODUCT NAME DISPLAY

Touchscreen can be set up to display any of 22 pre-programmed product descriptions with capability to add five (5) additional products

WALL MOUNTABLE/COMPACT DESIGN

Touchscreen and expander/junction box include built-in wall mount feature for ease of installation. Wall-mounted boxes take up less space and gets wiring out of the way of the user

PASSWORD PROTECTION

Programmable password for the highest level of accuracy

SPECIFICATIONS

Electrical Requirements	120 VAC, 60HZ
Fluid Solenoid	3,000 PSI Maximum, 1/2" NPT (F)
Pulse Meter	1,000 PSI Maximum, 1/2" NPT (F)
System Capacity	Single Product, 1 to 12 Dispensing Points or 2 Products, 1 to 6 Dispensing Points Each
System Requirements	Properly Sized Thermal Relief Kit Required
Wiring Requirements	22 Ga = <150'
	18 Ga = 151' - 250'
	16 Ga = 251' - 500'

FLUID COMPATIBILITY



Antifreeze Mixtures



Automatic Transmission Fluid



Gear Oil



Hydraulic Oil



Motor Oil



Synthetic Oil

<p>2003</p>	<p>Big ALEC V Fluid Inventory Control System Includes touchscreen, expander/junction box, 14' connection cable (not shown), <i>TIM-2000-5</i> 1/2" NPT pulse meter, <i>TIM-2000-37</i> 1/2" NPT 1/2" fluid solenoid valve, <i>TIM-2000-36</i> ready light assembly, <i>TIM-1404-88</i> 1/2" union adapter and <i>2000-24AC</i> powerpack and manual. Touchscreen can be wall-mounted using built-in mounting feature. Dispense one (1) product to one (1) dispensing point. Expandable up to twelve (12) dispensing points (stations), for one (1) product, by ordering <i>TIM-2000-1</i> add-on station kit. Can be connected to an air solenoid kit (order <i>TIM-2000-2</i> separately). <i>Requires PR-750 pressure relief kit (order separately)</i></p>
<p>2003-P2</p>	<p>Big ALEC V Two-Product Fluid Inventory Control System For two (2) product applications. Same as <i>2003</i> except with an additional pulse meter, fluid solenoid and ready light. Expandable up to six (6) dispensing points per product by ordering additional <i>TIM-2000-1</i> add-on station kits. <i>Requires PR-750 pressure relief kit (order separately)</i></p>
<p>2003-REP</p>	<p>Replacement Keypad Can be used to replace the <i>TIM-2002</i> Big ALEC IV. Includes touchscreen, expander box, 14' connection cable (not shown), 24VAC powerpack and manual. Touchscreen can be wall-mounted using built-in mounting feature. <i>Requires PR-750 pressure relief kit (order separately)</i></p>



ACCESSORIES

<p>2003-14CAT</p>	<p>14' CAT 5 Cable for Big ALEC V 14 foot. Interconnects <i>2003-CON</i> touchscreen and <i>2003-BOX</i> expander</p>
<p>PR-750</p>	<p>Pressure Relief Kit Relieves pressure build up in the fluid line due to thermal expansion. Includes tee connection, relief valve, rubber hose and 2" steel adapter. Relief set at 750 PSI. Use on 3:1 and 5:1 pumps. <i>A pressure relief kit is required on all 2003 fluid inventory control systems</i></p>
<p>TIM-2000-1</p>	<p>Add-On Station Kit For adding additional dispensing stations to the control console. Includes 3,000 PSI 1/2" fluid solenoid valve with inlet filter, 1/2" union adapter and ready light assembly.</p>
<p>TIM-2000-2</p>	<p>1/4" Air Solenoid Safety Kit For pumps with 1/4" air inlets. Shuts off air flow to the pump when fluid inventory control system is inactive. Helps prevent potential oil spills. Must be connected to expander/junction wiring box.</p>
<p>TIM-2000-2A1</p>	<p>1/2" Air Solenoid Safety Kit For pumps with 1/2" air inlets. Shuts off air flow to the pump when fluid inventory control system is inactive. Helps prevent potential oil spills. Must be connected to expander/junction wiring box.</p>
<p>TIM-2000-3A</p>	<p>Wire Spool 500' spool of 2-conductor 22-gauge wire</p>
<p>TIM-2000-5</p>	<p>Replacement Pulse Meter 1,000 PSI maximum working pressure, bi-directional, compatible with oils, 1/2" NPT (F) x 1/2" NPT (F), 378 pulses/gallon, 100mA max current, 28V max voltage, 3W max load <i>Big ALEC III, Big ALC IV and Big ALC V F.I.C. systems only. Not for use with antifreeze</i></p>
<p>TIM-2000-6A</p>	<p>1/2" Y-Strainer 200 PSI maximum working pressure at 100°F. Used for keeping contaminants out of the system. Direction of oil flow is into center of 14 mesh filter.</p>
<p>TIM-365-5S</p>	<p>Pulse Meter 1,000 PSI maximum working pressure, 1/2" NPT (F). 40 pulse per gallon old style mechanical pulse meter for older Big ALEC and Little ALEC systems. Will also work on many competitive systems which use mechanical pulse meters. Handles antifreeze and antifreeze solutions as well as oils. <i>Should be used in place of standard pulse meter when pumping antifreeze</i></p>
<p>TIM-6</p>	<p>Oil Bar Adapter Kit Used to connect fluid dispensing system solenoid valve to an oil bar. Use one (1) kit per outlet.</p>



SELF-EVACUATING WASTE OIL DRAINS

SELF-EVACUATING

Connect the house air supply directly to the preset regulator to evacuate the oil from the drain into any bulk waste oil storage tank

LARGE CAPACITY

24-gallon capacity allows user to perform more oil changes before having to evacuate the unit

EXPANSION FUNNEL

Removable plastic drain bowl expansion funnel with built-in filter screen provides support for draining oil filters

BUILT-IN FLUID GAUGE

Allows operator to see the oil level in the waste oil drain

4-WHEEL SWIVEL DESIGN

Allows easy maneuverability, including on uneven surfaces



TIM-317-A

HEAVY-DUTY

Heavy-duty all-steel tank stands up to the harshest environments

DRAIN BOWL

Metal drain bowl has built-in filter screen to prevent foreign matter from entering the drain

DRAIN HOSE

Clear discharge hose with curved nozzle simplifies evacuation

SAFETY

Unit incorporates a tamper resistant air regulator with air gauge and a safety pop-off valve to prevent over pressurization

TIM-317-A

Self-Evacuating "Pumpless" Waste Oil Drain

Uses standard shop air set at 8 PSI to evacuate the drain into a waste oil holding tank. 24-gallon steel tank for use with used oils. Safety pop-off valve prevents over pressurization. Includes removable storage tray, built-in fluid gauge, 7' discharge hose with curved nozzle and manual shut-off valve, articulating 15-3/4" diameter metal drain bowl (TIM-317-37C) with oil filter draining screen and 24" removable plastic drain bowl expansion funnel (TIM-317-39). Stem adjusts 51" to 78". Powder-coated black paint. Assembly required.

Order **2608** air connector and **210** air coupler separately

TIM-317-CAM

Self-Evacuating "Pumpless" Waste Oil Drain

Uses standard shop air set at 8 PSI to evacuate the drain into a waste oil holding tank. 24-gallon steel tank for use with used oils. Safety pop-off valve prevents over pressurization. Includes removable storage tray, built-in fluid gauge, 6' discharge hose with camlock connector and manual shut-off valve, articulating 15-3/4" diameter metal drain bowl with oil filter draining screen and 24" removable plastic drain bowl expansion funnel. Stem adjusts 51" to 78". Powder-coated black paint. Assembly required.

This unit is designed to work in conjunction with **TIM-CONV-CAM** conversion hose kit and **TIM-370-3M** overfill alarm which must be ordered separately

HOSE KIT

TIM-CONV-CAM

Hose Kit

Facilitates the connection between the TIM-317-CAM self-evacuating waste oil drain and the waste oil tank. The kit contains a 3/4" x 10' oil evacuation hose, 3/4" camlock coupler, air coupler, 1/4" x 12' recoil air hose (for connection to the TIM-370-3M overfill alarm) and a poster with operating instructions for the TIM-317-CAM drain.

24-GALLON CONVENTIONAL WASTE OIL DRAIN

HEAVY-DUTY

Heavy-duty all-steel tank stands up to the harshest environment

DRAIN PAN

Metal drain bowl has built-in filter screen to prevent foreign matter from entering the drain

BUILT-IN FLUID GAUGE

Allows operator to see the oil level in the waste oil drain

DRAIN PLUG

1" drain plug on the bottom of the unit for easy cleaning



TIM-315-COMP2

LARGE CAPACITY

24-gallon capacity allows user to perform more oil changes before having to evacuate the unit

EXPANSION FUNNEL

Removable plastic drain bowl expansion funnel with built-in filter screen provides support for draining oil filters

4-WHEEL DESIGN

Allows easy maneuverability, including on uneven surfaces

TIM-315-COMP2

Large Capacity Waste Oil Drain

24-gallon (90 liter) steel waste oil drain for use with waste oil evacuation pumps. Holds 50% more waste oil than standard 16-gallon drum-mounted waste oil drains. Unit has an articulating 15-3/4" diameter metal drain bowl with an oil filter draining screen and a 24" removable plastic drain bowl expansion funnel. Single piece holding tank prevents oil leaks commonly associated with waste oil drains that use 16-gallon drums. Includes removable storage tray, built-in fluid gauge and 3/4" fluid quick disconnect (*TIM-181*). Designed to work with 612999-4 and 612999-5 waste oil evacuation systems. Stem adjusts 48-1/2" to 76". Powder-coated black paint.

*Replaces **TIM-315-A** and **TIM-315-1A** waste oil drains*

Assembly required

SELF-EVACUATING WASTE OIL EXTRACTORS

SELF-EVACUATING

Connect the house air supply directly to the preset regulator to evacuate the oil from the drain into any bulk waste oil storage tank

SUCTION WANDS

Variety of flexible wands and adapters included

BUILT-IN FLUID GAUGE

Allows operator to see the oil level in the waste oil drain

DRAIN PLUG

1" drain plug on the bottom of the unit for easy cleaning



TIM-340

LARGE CAPACITY

24-gallon capacity allows user to perform more oil changes before having to evacuate the unit

VACUUM GAUGE

Robust gauge ensures peak performance

4-WHEEL SWIVEL DESIGN

Allows easy maneuverability, including on uneven surfaces

TIM-340

Self-Evacuating Waste Oil Extractor

24-gallon waste oil extractor utilizes shop air to extract oil via suction probes directly into the units holding tank. Collecting waste oil can then be evacuated from the 24-gallon tank into larger waste oil tanks using shop air. Features an easy to read vacuum gauge for suction and safety pop-off valve to prevent over pressurization. Includes removable storage tray, built-in fluid gauge, 7' discharge hose, suction hose and 6-piece probe set. Power-coated black paint.

Assembly required

TIM-341

Self-Evacuating Combo Waste Oil Extractor/Drain

24-gallon combination waste oil extractor/drain utilizes shop air to extract oil via suction probes directly into the units holding tank as well as the traditional method of draining oil through the drain bowl into the tank. Collected waste oil can then be evacuated from the 24-gallon tank into larger waste oil tanks using shop air. Features include 15-3/4" articulating metal drain bowl with 24" plastic expansion funnel and oil filter draining screen, easy to read vacuum gauge for suction and safety pop-off valve to prevent over pressurization. Includes removable storage tray, built-in fluid gauge, 7' discharge hose, suction hose and 6-piece probe set. Power-coated black paint.

Assembly required



TIM-341

LOW PROFILE TRUCK DRAIN



TIM-310*

20-Gallon Waste Oil & Antifreeze Drain

For truck maintenance facilities. Heavy-duty steel unit is powder-coated red. Drain has 5" diameter caster wheels, 38" long handle, 3/4"(M) drain connection and elbow. Designed to mate with 612999-4 or 612999-5 diaphragm pump evacuation system.

Dimensions: 48" L x 31" W x 7-1/2" H.

* Order **TIM-181-N** waste oil evacuation adapter kit separately

OIL SINK



TIM-OIL-SINK

Heavy Duty Waste Oil Sink

135-gallon steel waste oil sink - finish painted red

Dimensions: 36" L x 36" W x 42" H.

LABELING KITS

TIM-LABEL-KIT

Antifreeze Label Kit

Includes four (4) 11" x 2" *Antifreeze Only* labels and one (1) 2" x 2" *Evacuate Drain Into Waste Antifreeze Tanks Only* labels. Ideal for use with *TIM-317-A* self-evacuating waste oil drains and *TIM-315-COMP2* waste oil drains.

WASTE-LABEL-KIT

Waste Oil Label Kit

Includes four (4) 11" x 2" *Waste Oil Only* labels and one (1) 2" x 2" *Evacuate Drain Into Waste Oil Tanks Only* labels. Ideal for use with *TIM-317-A* self-evacuating waste oil drains and *TIM-315-COMP2* waste oil drains.

POLYETHYLENE DRAINS

TIM-318

8-Gallon Waste Oil Drain

Drain has built-in handle, emptying spout and four (4) wheels for easy maneuvering. Oil level can be viewed through translucent body. Height adjusts from 48" to 65".

TIM-319

18-Gallon Waste Oil Drain

Drain has built-in handle, emptying spout, 2" NPT (F) opening with plug, gate valve for gravity draining and four (4) wheels for easy maneuvering. Oil level can be viewed through translucent body. Height adjusts from 55" to 73".



TIM-318

REPLACEMENT BOWLS

TIM-315-BOWL	15" Metal Replacement Bowl for TIM-315 Series Drains Replacement bowl assembly for <i>TIM-315-1A</i> waste oil drain. Includes bowl, filter, adapter and pipe nipple. Compatible with <i>TIM-317-39</i> 24" plastic funnel extender.
TIM-315-KIT	Replacement Bowl Assembly for TIM-315-1A Waste Oil Drain Includes bowl, filter, adapter, pipe nipple and <i>TIM-317-39</i> 24" plastic funnel extender
TIM-316A-BOWL	15" Metal Replacement Bowl for TIM-316 Series Drains Can be used with <i>TIM-FUNNEL</i> drain expansion funnel
TIM-316A-KIT	15" Metal Replacement Bowl & Expansion Funnel for TIM-316 Series Drains
TIM-317-37C	15.75" center mount replacement drain bowl for <i>TIM-317-A</i> or <i>TIM-317-CAM</i> waste oil drain
TIM-317-PAN	Transmission Funnel Steel construction with large collection area measuring 32" x 21-3/4". Adapts to drain model number <i>TIM-317</i> . For use in transmission shops.
TIM-318-BOWL	16" Replacement Bowl for TIM-318 & TIM-319 Drains



TIM-315-BOWL



TIM-316A-KIT



TIM-318-BOWL

WASTE OIL TANK OVERFILL ALARM



TIM-370-3M

Waste Oil Tank Overfill Alarm & Pump Shut-Off Assembly

Used to shut off the air supply to the pump when the tank approaches full capacity. When the unit shuts the air off to the pump, air is diverted to a whistle mounted on the unit to signal that the tank is full. The valve is automatically reset when the tank is empty and the air pressure is turned off. Mounts into a 2"(F) NPT tank opening. ULC listed under overfill protection devices, type B, for pressure fill applications. Air inlet/outlet 1/4"(F) NPT. 100 PSI maximum. Air flow capacity 20 CFM at 100 PSI.

WASTE OIL ACCESSORIES



TIM-2000-10

1" NPT Y-Strainer

Two (2) 1" NPT (F) ports. Material: stainless steel. Removable 2mm filter. 230 PSI working pressure. Installs on suction side of waste oil system to prevent contaminants from causing costly damage to the waste oil diaphragm pump.

NOTE: See arrow on body for oil flow direction



TIM-WAND-1

Waste Oil Evacuation Wand

For TIM-319 waste oil drains. 22" metal tube is coupled to a TIM-181 fluid connector and strainer. Designed to mate with ARO 612999-4 or 612999-5 diaphragm pump evacuation systems.

1" DIAPHRAGM PUMP REVERSING VALVE



RV-1

1" 4-Way Evacuation Valve

Used in waste oil application to reverse the flow direction of the diaphragm pump. Inlet and outlet threads are 1"(F). For use with any 1" diaphragm pump.

WASTE OIL TANK EVACUATION KIT

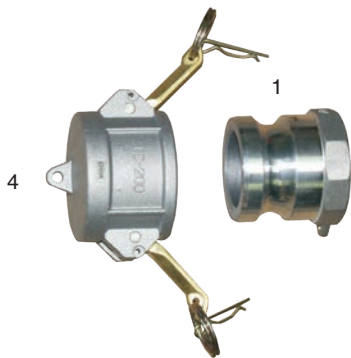

TIM-4676

Adapter Kit

Allows for easy evacuation of a waste oil tank. Includes *TIM-4676-1* 2"(F) camlock adapter (#1) and *TIM-4676-4* 2" camlock dust cap (#4). Adapter threads directly to a 2" contractor installed suction pipe running from ground level back to the waste oil tank.

FLUID CONNECTOR KITS



TIM-181-N

Waste Oil Drain Adapter Kit

Use with *TIM-310* truck drain. Enables drains to be used with ARO wall mount oil evacuation systems. Includes 3/4" fluid connector and 3/4" nipple.

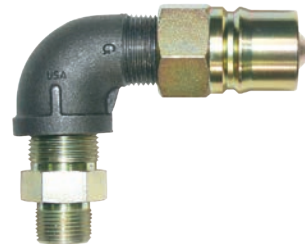

TIM-181-G

Waste Oil Drain Adapter Kit Assembly

Enables American Lubrication drain to be used with an existing Graco wall-mounted oil evacuation system. Includes 3/4"(M) x 1"(M) adapter, 1" street elbow and 1" fluid connector.

*Fluid connector is compatible with **TIM-182** fluid coupler*

FLUID COUPLERS & CONNECTORS

Used in oil evacuation system for quick disconnect of diaphragm pump and suction discharge hoses

Thread Size	Fluid Coupler	Fluid Connector	Max PSI
1/2"(F)	TIM-178	TIM-179	5,000 PSI
3/4"(F)	TIM-180	TIM-181	3,625 PSI
1"(F)	TIM-182	TIM-183	4,000 PSI



TIM-178



TIM-179

CAMLOCKS & CONNECTORS

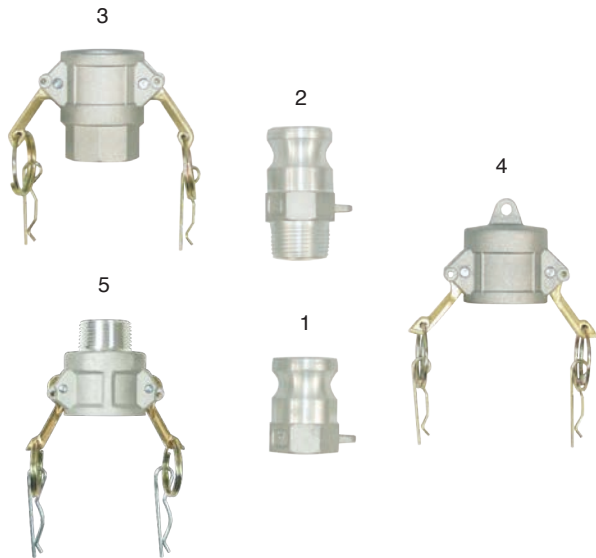

TIM-4670

TIM-4670-1	3/4" NPT (F) camlock adaptor
TIM-4670-2	3/4" NPT (M) camlock adaptor
TIM-4670-3	3/4" NPT (F) camlock coupler
TIM-4670-4	3/4" camlock dust cap
TIM-4670-5	3/4" NPT (M) camlock coupler



TIM-4675

TIM-4675-1	1" NPT (F) camlock adaptor
TIM-4675-2	1" NPT (M) camlock adaptor
TIM-4675-3	1" NPT (F) camlock coupler
TIM-4675-4	1" camlock dust cap



TIM-4676

TIM-4676-1	2" NPT (F) camlock adaptor
TIM-4676-2	2" NPT (M) camlock adaptor
TIM-4676-3	2" NPT (F) camlock coupler
TIM-4676-4	2" camlock dust cap

BULK OIL TANK PACKAGES

COST EFFECTIVE

Tank packages eliminate the installation expense associated with equipment installations

FAST DELIVERY

Large inventory enables most packages to ship within 48 hours

PROTECTIVE PACKAGING

Tank packages are covered with custom protective packaging

UL 142 & N.F.P.A. 30

All tanks are built on UL 142 and also meet the N.F.P.A. 30 specifications



275VDW-R23D

SIMPLE

Remove the protective packaging, connect the air hose, fill with oil, and your customer is up and running

MORE CHOICES

American Lubrication offers the broadest selection of tank packages on the market

ENAMEL PAINT

All tank packages come standard with an enamel painted finish

FRESH AND WASTE OIL PACKAGES

American Lubrication offers single and double-wall packages for fresh oil systems and waste oil systems



Most packages ship within 48 hours



Tanks built to UL 142 specifications



250-R25D



165DW-R23D



120BCDW-R23D



275A-R23D



500RVDW-RWO

MAIN APPLIES TO ALL PACKAGES

120B	120-Gallon Cube, White	275DW	275-Gallon Horizontal Obround Double-Wall
120BC	120-Gallon Portable Bench (on casters)	275AV	275-Gallon Vertical Obround
120BDW	120-Gallon Double-Wall Bench	275VDW	275-Gallon Vertical Obround Double-Wall
120BCDW	120-Gallon Portable Double-Wall Bench	C500	500-Gallon Cube
150RVDW	150-Gallon Double-Wall Round	C500DW	500-Gallon Double-Wall Cube
165	165-Gallon Bench	500RV	500-Gallon Vertical Round
165DW	165-Gallon Double-Wall Bench	500RVDW	500-Gallon Vertical Double-Wall
250	250-Gallon Bench	525RND	525-Gallon Round Skid
250DW	250-Gallon Double-Wall Bench	525DW	525-Gallon Horizontal Double-Wall
270RVDW	270-Gallon Double-Wall Round	525RDW	525-Gallon Vertical Round Double-Wall
275A	275-Gallon Horizontal Obround		

SUFFIX PUMP, REEL & METER PACKAGES

	R13D	R13P	R23D	R23P	X3X
Pump	3:1 ARO	3:1 ARO	3:1 ARO	3:1 ARO	3:1 ARO
Oil Reel	1/2" x 25'	1/2" x 25'	1/2" x 50'	1/2" x 50'	—
Meter	Quart Digital Meter	Preset Digital Meter	Quart Digital Meter	Preset Digital Meter	—
	R15D	R15P	R25D	R25P	X5X
Pump	5:1 ARO	5:1 ARO	5:1 ARO	5:1 ARO	5:1 ARO
Oil Reel	1/2" x 25'	1/2" x 25'	1/2" x 50'	1/2" x 50'	—
Meter	Quart Digital Meter	Preset Digital Meter	Quart Digital Meter	Preset Digital Meter	—

TAPPER PUMP PACKAGES

	R33	R33D
Pump	3:1 ARO	3:1 ARO
Accessories	Tapper	Tapper
Meter	No	Digital Quart In-Line

WASTE OIL PACKAGES

	RWO	RWOA
Diaphragm Pump	1" ARO	1" ARO
Hose End	Non-Spill Coupler	Non-Spill Coupler
Overfill Alarm	No	TIM-370-3M

ORDERING INFORMATION

Main

Suffix

(Pick from charts above)

Example: To order a 275-gallon horizontal obround tank package with a 3:1 pump, 1/2" x 50' black Advantage Plus Series reel and digital meter you would go to the Main column and select "275A", and then go to the Suffix column and under "Pump, Reel & Meter Packages" select "R23D". The final model number would be "275A-R23D".

	Gallons	Length	Width	Height	Gauge
UL BENCH (SINGLE-WALL)					
165B	170	33"	36"	37"	12
UL BENCH (DOUBLE-WALL)					
165BDW	170	45"	35"	37"	12
250BDW	249	69"	32"	36"	12
UL OBOURD TANKS - VERTICAL & HORIZONTAL (SINGLE-WALL)					
275H	268	60"	27"	47"	12
275V	268	44"	27"	62"	12
UL OBOURD TANKS - VERTICAL & HORIZONTAL (DOUBLE-WALL)					
275HDW	268	61"	27"	47"	12
275VDW	265	45"	27-3/4"	62"	12
UL CUBE (SINGLE-WALL)					
120B*	120	23"	34"	37.75"	12
120BC*	120	23"	34"	45"	12
500C	498	61"	34"	64"	10
UL CUBE (DOUBLE-WALL)					
120BDW*	120	34"	32"	40"	12
120BCDW*‡	120	34"	32"	40"	12
500CDW	499	72"	34"	64"	10
UL ROUND TANKS - VERTICAL & HORIZONTAL (SINGLE-WALL)					
500RV	495	50"	50"	64"	12
525RH	525	46"	74"	46"	12
UL ROUND TANKS - VERTICAL & HORIZONTAL (DOUBLE-WALL)					
500RVDW	490	50"	50"	64"	12
525RHDW	525	46"	74"	46"	12

All tanks on these sheets are painted with red enamel and are U.L. 142

* 120-Gallon tanks are painted white

‡ Tank is mounted on casters

All dimensions shown reflect outside measurements including lips, reel brackets, and lifting lugs. These measurements may vary slightly

All prices are FOB from shipping point, either Hunt Valley, MD or Anaheim, CA

All tanks include a reel mount bracket

Drawings available upon request

WARRANTY: We are advised that each tank is tested by the manufacturer at the factory before shipment in accordance with applicable Underwriters Laboratories standards, NFPA 30, 30A, or 31, OSHA and Uniform Fire Code requirements. Damage may occur during shipment that is not apparent by visual inspection. National and state codes require testing at the job site by the installer BEFORE installation. Single-wall tanks should be pressurized to a maximum of 3 PSI while all welds are tested with a soap solution as stated in instructions on the tank. Double-wall tanks must be tested in accordance with Petroleum Equipment Institute recommended practice RP100 or RP200 or with the manufacturer's published procedures. Tanks must be installed in strict accordance with NFPA 30, NFPA 30A or NFPA 31.

We assume no responsibility for damages, consequential or otherwise, resulting from defects in tanks or for damage to tanks occurring during shipment or installation. Manufacturers of these tanks generally limit their responsibility to repair or replacement of the tank for defects in workmanship or material. Any manufacturer's warranties will be passed through to the purchaser.

ROTH TANK PACKAGES

UNIQUE DOUBLE-WALL CONSTRUCTION

The outer tank is made of leak-proof, weld-free galvanized steel and roll-seamed with an oil and fire-resistant seal. It can contain 110% of the capacity of the inner tank for maximum protection. The inner tank is made of blow-molded high-density, seamless polyethylene.

LEAK INDICATOR

All Roth tanks are equipped with visible optical leak alarm

FLUID COMPATIBILITY

Engine oils, gear oils, transmission oils and hydraulic oils

WARRANTY

Roth tanks carry a 30-year limited warranty from the manufacturer



RUST RESISTANT

Inner and outer wall will never rust or corrode

AVAILABLE SIZES

Tank packages offered in 110-gallon, 165-gallon, 275-gallon and 400-gallon sizes

LIGHTWEIGHT

Wide handles and lightweight design makes Roth tanks easy to move before filling with oil

MAIN APPLIES TO ALL PACKAGES

	Gallons	Length	Width	Height	Weight
RT-110	110	29"	28"	44"	106 lbs
RT-165	165	29"	28"	61"	132 lbs
RT-275	275	43"	28"	61"	167 lbs
RT-400	400	64"	30"	72"	333 lbs

SUFFIX PUMP, REEL & METER PACKAGES

	R13D	R13P	R23D	R23P	X3X
Pump	3:1 ARO	3:1 ARO	3:1 ARO	3:1 ARO	3:1 ARO
Oil Reel	1/2" x 25'	1/2" x 25'	1/2" x 50'	1/2" x 50'	—
Meter	Quart Digital Meter	Preset Digital Meter	Quart Digital Meter	Preset Digital Meter	—

	R15D	R15P	R25D	R25P	X5X
Pump	5:1 ARO	5:1 ARO	5:1 ARO	5:1 ARO	5:1 ARO
Oil Reel	1/2" x 25'	1/2" x 25'	1/2" x 50'	1/2" x 50'	—
Meter	Quart Digital Meter	Preset Digital Meter	Quart Digital Meter	Preset Digital Meter	—

TAPPER PUMP PACKAGES

	R33T
Pump	3:1 ARO
Accessories	Tapper
Meter	No

WASTE OIL PACKAGES

	RUO
Diaphragm Pump	1" ARO
Hose End	Non-Spill Coupler
Overfill Alarm	No

OIL BAR PUMP PACKAGES

	3BAR
Pump	3:1 ARO
Single Spigot Oil Bar	Tapper

ANTIFREEZE PUMP/REEL/METER PACKAGE

	R212D
Pump	1/2" Diaphragm Pump
Reel	50'
Control Handle	Digital

ORDERING INFORMATION

— RTDW —

Main

Suffix

(Pick from charts above)

Example: To order a 275-gallon Roth tank package with a 3:1 pump, 1/2" x 50' black Advantage Plus Series reel and digital meter you would go to the Main column and select "275" for the 275-gallon tank and then go to the Suffix column and under "Pump, Reel & Meter Packages" select "R23D". The final model number would be "275-RTDW-R23D".

These tank packages cannot be used for gasoline, windshield washer solvent or DEF

Tanks must be purchased with lubrication equipment

*Tanks are certified to UL SU2258 which includes combustible liquids addressed by the following material classes outlined in NFPA Standards 30, 30A and 31:
Class IIIA Liquid — any liquid that has a flash point at or above 140°F but below 200°F
Class IIIB Liquid — any liquid that has a flash point at or above 200°F*

STACKABLE POLY TANKS

SPACE

Poly stackable tanks are great for saving space in busy shops

AVAILABLE SIZES

Poly tanks available in 60, 80, 120, 180 & 260 gallon sizes

TRANSLUCENT

Liquid level is visible at all times



GF120-3K

CLEAN

Eliminate messy clutter from drum storage

LOW COST

Poly tanks are lower cost than steel storage tanks

BARE POLY STACKABLE TANKS

PT60	60-Gallon Poly Tank Dimensions: 36" W x 36" D x 18" H
PT80	80-Gallon Poly Tank Dimensions: 36" W x 36" D x 22" H
PT120	120-Gallon Poly Tank Dimensions: 36" W x 36" D x 31" H
PT180	180-Gallon Poly Tank Dimensions: 36" W x 36" D x 40" H
PT260	260-Gallon Poly Tank Dimensions: 36" W x 36" D x 58" H



PT60



PT260

GRAVITY FEED TANK SYSTEMS

GF60-3K	60/60/60 gravity feed system Dimensions: 40" x 48" x 70" H	GF80-120-2K	80/120/120 gravity feed system Dimensions: 40" x 48" x 100" H
GF60-4K	60/60/60/60 gravity feed system Dimensions: 40" x 48" x 83" H	GF120K	120 gravity feed system Dimensions: 40" x 48" x 55" H
GF60-2-120K	60/60/120 gravity feed system Dimensions: 40" x 48" x 83" H	GF120-2K	120/120 gravity feed system Dimensions: 40" x 48" x 83" H
GF60-2-180K	60/60/180 gravity feed system Dimensions: 40" x 48" x 95" H	GF120-3K	120/120/120 gravity feed system Dimensions: 40" x 48" x 108" H
GF80-2K	80/80 gravity feed system Dimensions: 40" x 48" x 65" H	GF120-180K	120/180 gravity feed system Dimensions: 40" x 48" x 95" H
GF80-3K	80/80/80 gravity feed system Dimensions: 40" x 48" x 83" H	GF180K	180 gravity feed system Dimensions: 40" x 48" x 68" H
GF80-4K	80/80/80/80 gravity feed system Dimensions: 40" x 48" x 100" H	GF180-2K	180/180 gravity feed system Dimensions: 40" x 48" x 108" H
GF80-2-120K	80/80/120 gravity feed system Dimensions: 40" x 48" x 91" H	GF260K	260 gravity feed system Dimensions: 40" x 48" x 82" H
GF80-120K	80/120 gravity feed system Dimensions: 40" x 48" x 74" H		



GF80-4K

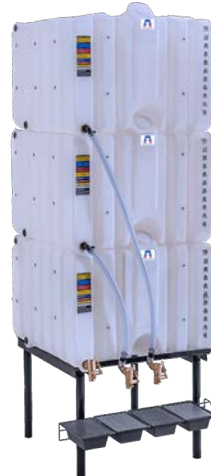

GF120-3K



GF180-2K

CONTAINER PANS



PT16



PT29

Description	203-gallon containment	390-gallon containment
Dimensions	52" x 58" x 20" H	62" x 76" x 28" H

TANK STANDS & ACCESSORIES

PT6	Ratchet strap - 1" x 16' with S hook
PT8	Steel stand - base only
PT12	Steel stand- 24" legs

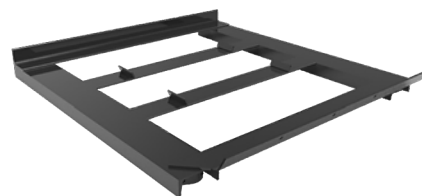

PT8

DRIP TRAYS

PT10	Drip tray kit - frame with 4 drip trays/screens
PT13	Drip tray - frame only
PT14	Drip tray inserts with screen only



PT14

GRAVITY FEED ACCESSORY PACKAGES

Includes 1" tubing, hose connectors, hose clamps, sealant, poly elbow and tank stand elbow kit

PT17	2-tank accessory package
PT18	3-tank accessory package
PT19	4-tank accessory package



PT18

GRAVITY FEED ACCESSORIES

PT9	Stainless steel spring release valve
PT20	Thread sealant
PT24	1" poly elbow
PT25	1" poly straight fitting
PT26	Hose clamp



PT24



PT25

TANK BRACKETS

PT1	Side mount tank bracket
PT2	Universal pump bracket with hardware kit
PT3	Universal hose reel bracket with hardware kit



PT3



PT2

IDENTIFICATION LABEL

PT41	Black identification placard, 18" x 24"
-------------	---



PT41

LUBE EQUIPMENT PACKAGES

PT200-R23D	<p>Lube Equipment Package for Poly Tanks 120-Gallon or Larger Includes 3:1 oil pump, piggyback air filter/regulator with gauge, air coupler, air connector, 1/4" x 5' air hose, 1" shut-off valve, 1" ID x 32" clear plastic suction hose, union adapters, vented fill cap, 2.5' oil connecting hose, 1/2" x 50' oil reel package, digital metered control handle, side mount tank bracket, pump bracket and reel bracket.</p>
PT200-R23N	<p>Lube Equipment Package for Poly Tanks 120-Gallon or Larger Includes 3:1 oil pump, piggyback air filter/regulator with gauge, air coupler, air connector, 1/4" x 5' air hose, 1" shut-off valve, 1" ID x 32" clear plastic suction hose, union adapters, vented fill cap, 2.5' oil connecting hose, 1/2" x 50' oil reel package, non-metered control handle, side mount tank bracket, pump bracket and reel bracket.</p>
PT200-R23P	<p>Lube Equipment Package for Poly Tanks 120-Gallon or Larger Includes 3:1 oil pump, piggyback air filter/regulator with gauge, air coupler, air connector, 1/4" x 5' air hose, 1" shut-off valve, 1" ID x 32" clear plastic suction hose, union adapters, vented fill cap, 2.5' oil connecting hose, 1/2" x 50' oil reel package, preset digital metered control handle, side mount tank bracket, pump bracket and reel bracket.</p>
PT201-R212D	<p>Antifreeze or Windshield Washer Solvent Equipment Package for Poly Tanks 120-Gallon or Larger Includes 1/2" top mounted diaphragm pump, piggyback air filter/regulator with gauge, air coupler, air connector, 1/2" x 5' air hose, vented fill cap, 2.5' material connecting hose, 1/2" x 50' reel package, digital metered control handle, side mount tank bracket and reel bracket.</p>
PT201-R212N	<p>Antifreeze or Windshield Washer Solvent Equipment Package for Poly Tanks 120-Gallon or Larger Includes 1/2" top mounted diaphragm pump, piggyback air filter/regulator with gauge, air coupler, air connector, 1/4" x 5' air hose, vented fill cap, 2.5' material connecting hose, 1/2" x 50' reel package, non-metered control handle, side mount tank bracket and reel bracket.</p>

Order tank(s), tank stand and ratchet straps separately.



PT200-R23D
(tanks not included)



PT201-R212D
(tank not included)

TOTE PUMPING SYSTEMS

MOUNTING PLATE

Heavy-duty steel mounting plate

VERSATILE

Turns totes into a functional tank package

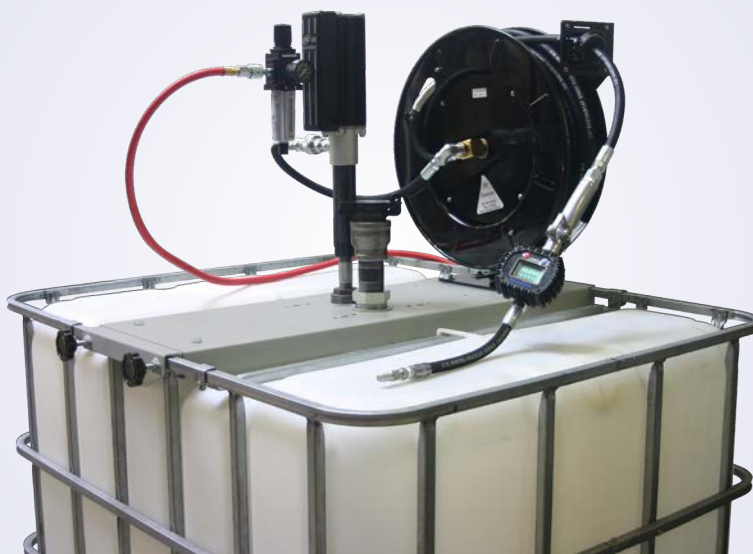

PRE-DRILLED

Pre-drilled holes for Advantage Series reels

FLEXIBILITY

Fits most totes

3:1 PUMPS

	RPM-3-TM1	RPM-3-TM2	RPM-3-TM3
Pump	LM2203A-11-C	LM2203A-11-C	LM2203A-11-C
Mounting Bracket	TIM-464-A	TIM-464-A	TIM-464-A
Reel (50')	TIM-3628-50	TIM-3628-50	TIM-3628-50
Filter/Regulator/Gauge	P-39224-624	P-39224-624	P-39224-624
Control Handle	TIM-601-FM	TIM-900B-1	TIM-762-TG
Oil Connecting Hose	TIM-4418-2NS	TIM-4418-2NS	TIM-4418-2NS
Filter/Regulator to Pump Adapter	TIM-212-1	TIM-212-1	TIM-212-1
Fluid Coupler	TIM-178	TIM-178	TIM-178
Fluid Connector	TIM-179	TIM-179	TIM-179
Air Connecting Hose	AIR-HP1414-5	AIR-HP1414-5	AIR-HP1414-5
Downtube	TIM-MTL75-33	TIM-MTL75-33	TIM-MTL75-33
Low-Level Cutoff	TIM-196-C	TIM-196-C	TIM-196-C

5:1 PUMPS

	RPM-5-TM1	RPM-5-TM2	RPM-5-TM3
Pump	LM2305A-11-B	LM2305A-11-B	LM2305A-11-B
Mounting Bracket	TIM-464-A	TIM-464-A	TIM-464-A
Reel (50')	TIM-3628-50	TIM-3628-50	TIM-3628-50
Filter/Regulator/Gauge	P-39224-624	P-39224-624	P-39224-624
Control Handle	TIM-601-FM	TIM-900B-1	TIM-762-TG
Oil Connecting Hose	TIM-4418-2NS	TIM-4418-2NS	TIM-4418-2NS
Filter/Regulator to Pump Adapter	TIM-212-1	TIM-212-1	TIM-212-1
Fluid Coupler	TIM-178	TIM-178	TIM-178
Fluid Connector	TIM-179	TIM-179	TIM-179
Air Connecting Hose	AIR-HP1414-5	AIR-HP1414-5	AIR-HP1414-5
Downtube	TIM-MTL-35	TIM-MTL-35	TIM-MTL-35
Low-Level Cutoff	TIM-166-LLC	TIM-166-LLC	TIM-166-LLC

1/2" DIAPHRAGM PUMPS

	NEW RPM-12-TM1AL	NEW RPM-12-TM3AL
Pump	TIM-734-TAL	TIM-734-TAL
Mounting Bracket	TIM-464-A	TIM-464-A
Reel (50')	TIM-3628-50	TIM-3628-50
Filter/Regulator/Gauge	P-39224-624	P-39224-624
Control Handle	TIM-601-FM	TIM-762-TG
Oil Connecting Hose	TIM-4418-2NS	TIM-4418-2NS
Filter/Regulator to Pump Adapter	TIM-212-1	TIM-212-1
Fluid Coupler	TIM-178	TIM-178
Fluid Connector	TIM-179	TIM-179
Air Connecting Hose	AIR-HP1414-5	AIR-HP1414-5
Downtube	TIM-MTL75-33	TIM-MTL75-33
Low-Level Cutoff	TIM-196-C	TIM-196-C

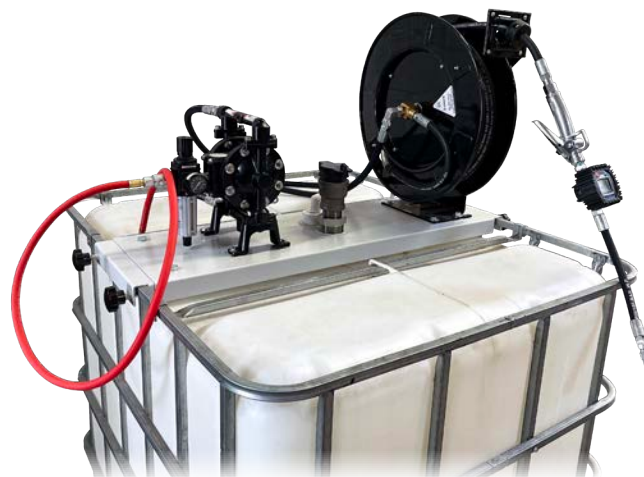

RPM-12-TM1AL

TOTE TRANSFER DIAPHRAGM PUMP SYSTEM

TIM-766

Tote Transfer Pump System for Oil

Includes 1" diaphragm pump, air coupler, air connector, air filter/regulator with gauge, 5' air connecting hose, tote top mounting bracket, fill cap, suction tube, inlet check valve and low level cutoff, 1" x 5' suction hose, 1" x 15' delivery hose, and high output non-metered control handle



TIM-766

DOUBLE-TAP BUSHINGS

TIM-160

2" NPT (M) x 1-1/2" NPT (F) Double-Tap Bushing

For mounting 5:1 or 9:1 stub pumps to an above-ground tank. Replaces bung adapter mounting. Extension tube of pump screws directly into the bottom of the bushing. Outside thread is 2"(M), inside thread is 1-1/2"(F).

*When using with an ARO 5:1 Thunder pump, order **TIM-211** (1-1/2" x 3" nipple) separately*

TIM-190

3" NPT (M) x 2" NPT (F) Reducing Bushing

For converting a 3"(F) threaded tank opening to 2"(F). Enables tank mounting of oil pump via 2" bung adapter. Outside thread is 3"(M) and inside thread is 2"(F).

TIM-198

2" NPT (M) x 3/4" NPT (F) Double-Tap Bushing

For mounting Thunder 3:1 stub pumps directly to an above-ground tank. Replaces bung adapter mounting. Extension tube of pump screws directly into the included 3/4" x 3" nipple. Outside thread is 2"(M), inside thread is 3/4"(F).



TIM-160

FILL CAPS



TIM-FILL-CAP

2"(M) Vented Lockable Fill Cap

For above-ground tanks

TANK VENTS

TIM-MUSH-VENT	2"(F) Mushroom Vent Order <i>TIM-287</i> (2" close nipple) separately
TIM-VENT-2	2" Emergency Vent For use with bulk oil storage tanks
TIM-VENT-3	3"(M) Emergency Vent Designed for use with bulk oil storage tanks
TIM-VENT-4S	4"(M) Emergency Vent Slim design allows for use on both single and double-wall tanks
TIM-VENT-6	6"(M) Emergency Vent Design for use with bulk oil storage tanks



TIM-MUSH-VENT



TIM-VENT-3

3-1/2 GALLON AST SPILL CONTAINER



TIM-SPILL-BOX3

Lockable Spill Container

Installed on above-ground tanks to contain small spills and drips from the fill nozzle. Removable screen allows for used filters to be drained. 2" NPT (M) riser connection. White powder-coated finish. 3-1/2 gallon capacity. ULC listed.

Dimensions: 14" diameter, 6" high

TANK PLUGS

	TIM-PLUG-3/4	TIM-PLUG-1	TIM-PLUG-2	TIM-PLUG-3	TIM-PLUG-4	TIM-PLUG-6
Description	3/4" Tank Plug	1" Tank Plug	2" Tank Plug	3" Tank Plug	4" Tank Plug	6" Tank Plug
Material	Iron	Steel	Steel	Steel	Steel	Plastic



TIM-PLUG-3/4



TIM-PLUG-4

LEAK DETECTION SITE GLASS



75-TA-INSP

Secondary Containment Site Glass

Brass site glass with 3/4"(M) thread to be installed in the inspection port of the secondary containment wall of either the 275VDW or 500RVDW tank to detect a primary compartment leak

PLASTIC FLOAT & STRING GAUGES

	Metered Units	Length	Tank Used On
TG-32	Inches	32"	Workbench Tanks
TG-36	Inches	36"	165 & 250-Gallon Bench Tanks with 36" Interior Height
TG-275H	Gallons	44"	275-Gallon Horizontal Obround
TG-44	Inches	44"	275-Gallon Horizontal Obround
TG-46	Inches	46"	525-Gallon Horizontal Round
TG-60	Inches	60"	275-Gallon Vertical Obround, 500-Gallon & Larger Cube Tanks
TG-72	Inches	72"	Tanks with 72" Interior Height



TG-32



TIM-GG-60

METAL FLOAT & STRING GAUGES

	Metered Units	Length	Tank Used On
BK-001	Inches	99"	All Tanks
TIM-GG-44	Gallons	44"	275-Gallon Horizontal Obround
TIM-GG-60	Inches	60"	275-Gallon Vertical Obround, 500-Gallon Vertical Round & Larger Cube Tanks
TIM-GG-72	Inches	72"	Tanks with 72" Interior Heights



BK-001

SWING ARM TANK GAUGES

	Metered Units	Length	Tank Used On
TIM-H2-32	8ths of a Tank	32"	165 & 250-Gallon Bench Tanks
TIM-D2-36	8ths of a Tank	36"	120-Gallon Bench Tanks
TIM-D2-44	8ths of a Tank	44"	275-Gallon Horizontal Obround
TIM-D2-48	8ths of a Tank	48"	525-Gallon Horizontal Round
TIM-H2-60	8ths of a Tank	60"	275-Gallon Vertical Obround, 500-Gallon & Larger Cube Tanks



TIM-H2-60

QUICK-LUBE PIT DRAIN



QL-308

35-Gallon Rolling Waste Oil Drain

For use in quick-lube facilities or truck maintenance shops.

Heavy-duty steel unit is powder-coated yellow. Angled wheels provide easy drain movement and can be adjusted from 34" to 46". Drain bottom is sloped toward the two screened drain holes on the front and the rear of the unit. Drain holes are 1"(M). Drain includes pull handles on the front and rear of the unit, filter screen, and internal baffling.

Dimensions: 31" L x 30-3/4" W x 11" H

Order **TIM-4675** camlock kit, **TIM-1001-BV** ball valve and **TIM-4416-3** or **TIM-4416-8** suction hose separately

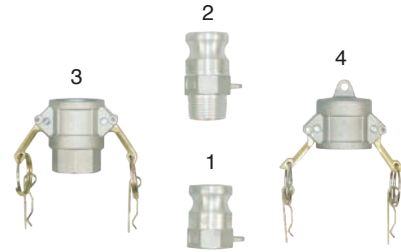

TIM-4675

Waste Oil Adapter Kit

Allows **QL-308** pit drain to be used in gravity drain or diaphragm pump evacuation systems. Includes 1"(M) camlock adapter (#2) with dust cap (#4) for pit drain, 1" camlock coupler (#3) for suction hose and 1" camlock adapter (#1) to be used as a suction hose hanger.

STEP STOOL



QL-101

Step Stool

Durable lightweight aluminum construction features wide angled base with padded feet and molded non-slip surface for added safety. This stool weighs only 10 pounds.

Dimensions: 20-1/2" D x 20-1/2" W x 10-1/2" H

Order **QL-101-PAD** replacement feet pads separately. Sold individually.

12-HOLE CONSOLE



QL-702-SSR

Stainless Steel 12-Hole Console, 2 Tier

For quick lube applications. Internal opening dimensions are 29-1/2" x 11-3/4".

AIR FILTERS

	Thread Size	Series	Drain Type	Bowl Type	Air Flow
F-100	1/4"	ALEC	Automatic	Metal	20 CFM
F35121-421	1/4"	1000	Automatic	Metal	49 CFM
F35221-411	1/4"	1500	Automatic	Metal	73 CFM
F35231-411	3/8"	1500	Automatic	Metal	107 CFM
F35331-410	3/8"	2000	Manual	Metal	156 CFM
F35341-400	1/2"	2000	Manual	Polycarbonate	197 CFM
F35341-410	1/2"	2000	Manual	Metal	197 CFM
F35351-411	3/4"	2000	Automatic	Metal	216 CFM
F35451-410	3/4"	3000	Manual	Metal	288 CFM

ARO®



F35341-400

AIR REGULATORS

	Thread Size	Series	Pressure Range	Gauge Included	Air Flow
R37121-100	1/4"	1000	0 to 140 PSI	No	59 CFM
R37221-100	1/4"	1500	0 to 140 PSI	No	86 CFM
R37221-200	1/4"	1500	0 to 140 PSI	No	86 CFM
R-37221-600T	1/4"	1500	0 to 140 PSI	Yes	86 CFM
R37231-600	3/8"	1500	0 to 140 PSI	Yes	113 CFM
R37331-600	1/2"	2000	0 to 140 PSI	Yes	179 CFM
R37341-100	1/2"	2000	0 to 140 PSI	No	210 CFM
R37341-600	1/2"	2000	0 to 140 PSI	Yes	210 CFM
R37351-100	3/4"	2000	0 to 140 PSI	No	210 CFM



R37331-600

AIR LUBRICATORS

	Thread Size	Series	Bowl Capacity	Bowl Type	Air Flow
L36121-100	1/4"	1000	0.7 oz	Metal	57 CFM
L36221-110	1/4"	1500	1.5 oz	Metal	51 CFM
L36331-110	3/8"	2000	1.5 oz	Metal	85 CFM
L36341-110	1/2"	2000	3.7 oz	Metal	156 CFM
L36351-110	3/4"	2000	10 oz	Metal	222 CFM



L36341-110

AIR FILTER/REGULATOR & GAUGE ASSEMBLIES

	Thread Size	Series	Drain Type	Bowl Type	Air Flow
P39124-124*	1/4"	1000	Automatic	Metal	47 CFM
P-39124-624	1/4"	1000	Automatic	Metal	47 CFM
P-39224-624	1/4"	1500	Automatic	Metal	72 CFM
P39234-614	3/8"	1500	Automatic	Metal	90 CFM
P39344-614	1/2"	2000	Automatic	Metal	172 CFM
P39354-614	3/4"	2000	Automatic	Metal	173 CFM

* Does not include gauge

ARO®



P-39224-624

FILTER/REGULATOR/LUBRICATOR ASSEMBLIES

	Thread Size	Series	Drain Type	Bowl Type	Air Flow
C38121-801	1/4"	1000	Automatic	Polycarbonate	46 CFM
C38221-810	1/4"	1500	Manual	Metal	61 CFM
C38221-811	1/4"	1500	Automatic	Metal	61 CFM
C38331-811	3/8"	2000	Automatic	Metal	99 CFM
C38341-810	1/2"	2000	Manual	Metal	150 CFM
C38351-811	3/4"	2000	Automatic	Metal	171 CFM

All models include built-in air gauge and sight gauge



C38351-811

AIR GAUGES

	TIM-220	TIM-221
Thread Size	1/8"(M)	1/4"(M)
Series Used On	1000, 1500 & ALEC	2000 & 3000
Porting	Back	Back
Gauge Range	0 to 160 PSI	0 to 160 PSI
Gauge Diameter	1.5"	2"



TIM-220

AIR SYSTEM PIPE NIPPLES

	TIM-212-1	Y-27-53C	Y-27-54C	Y-27-55C
Thread Size	1/4"(M) x 1/4"(M)	3/8"(M) x 3/8"(M)	1/2"(M) x 1/2"(M)	3/4"(M) x 3/4"(M)
Used On	1/4" Components	3/8" Components	1/2" Components	3/4" Components



Y-27-53C



Y-27-54C

ARO STYLE 1/4" CAPACITY - 210 SERIES

All couplers are "push-to-connect" providing automatic pin-type coupling. The average flow rate is 18 CFM at 90 PSIG inlet pressure. Maximum inlet pressure is 250 PSIG. Temperature range is -40°F to 200°F. Couplers and connectors within the 1/4" capacity 210 Series group are interchangeable.

COUPLERS

	Thread Size
210-212	1/4" NPT (M)
210	1/4" NPT (F)
210-25*	1/4" NPT (F)

* 25 pack

CONNECTORS

	Thread Size
2607	1/8" NPT (M)
2608	1/4" NPT (M)
2608-25*	1/4" NPT (M)
2609	1/4" NPT (F)
2609-25*	1/4" NPT (F)

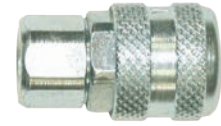

210



2608

MS SERIES 1/4" CAPACITY - INDUSTRIAL INTERCHANGE

All couplers are "push-to-connect" providing automatic pin-type coupling. The average flow rate is 36 CFM at 90 PSIG inlet pressure. Maximum inlet pressure is 250 PSIG. Temperature range is -40°F to 200°F. Couplers and connectors within the 1/4" capacity Industrial Interchange group are interchangeable.

COUPLERS

	Thread Size
MSCF22-000	1/4" NPT (F)
MSCF23-000	3/8" NPT (F)
MSCM22-000	1/4" NPT (M)

CONNECTORS

	Thread Size
23902-210	1/4" NPT (M)
23902-200	1/4" NPT (F)



MSCF22-000



23902-210

HIGH FLOW SERIES 3/8" CAPACITY - INDUSTRIAL INTERCHANGE

All couplers are "push-to-connect" providing automatic pin-type coupling. The average flow rate is 72 CFM at 90 PSIG inlet pressure. Maximum inlet pressure is 250 PSI. Temperature range is -40°F to 200°F. Couplers and connectors within the 3/8" capacity High Flow Series Industrial Interchange group are interchangeable.

COUPLERS

	Thread Size
23103-004	1/2" NPT (F)
23103-300	3/8" NPT (F)
23103-313	3/8" NPT (M)

CONNECTORS

	Thread Size
23903-300	3/8" NPT (F)
23903-310	3/8" NPT (M)
23903-410	1/2" NPT (M)



23103-004



23903-410



ARO-STOP® AUTOMATIC AIR SHUT-OFF

ARO-STOP® shut-off valves are designed to prevent pump “runaway”. Pump runaway occurs when the material container is depleted, causing the pump to cycle fast and needlessly. The ARO-STOP® valve protects the pump by shutting off the air supply when the material container is empty or a fluid line on the outlet side of the pump is broken. Use with oil or grease pumps.



635040



23644-400

Description	ARO-STOP® Valve Kit Includes 1/4" x 5' air hose, 1/4" ARO coupler and air connector. Maximum flow rate is 23 CFM at 90 PSI.	ARO-STOP® Valve Shuts off air to pump when material container is empty or fluid line is broken. Air inlet and outlet 1/2"(F).
Air Inlet/Outlet	1/4"(F)	1/2"(F)
Used On	Series 200 Pumps, All Thunder Pumps, 1/2" Diaphragm Pumps	AFX Series Pumps, 1" Diaphragm Pumps

AIR CONTROL BOX

TIM-AIR-BOX	110 VAC Electrical Box for Controlling Air to Pump(s) 110 VAC in, 24 VAC out, electrical box for controlling one (1) air solenoid plumbed to a pump or pumps. Includes key switch, 2A fuse and indicator light. Box is not rated for outdoor use. WARNING: Connecting the air box to two (2) air solenoids in parallel will result in transformer failure.
TIM-2000-2	1/4" Air Solenoid Safety Kit For pumps with 1/4" air inlets. Shuts off air flow to the pump when connected to the air control box (TIM-AIR-BOX). Helps prevent potential oil spills.
TIM-2000-2A1	1/2" Air Solenoid Safety Kit For pumps with 1/2" air inlets. Shuts off air flow to the pump when connected to the air control box (TIM-AIR-BOX). Helps prevent potential oil spills.
TIM-2000-3A	Wire Spool 500' spool of 2-conductor 22-gauge wire
TIM-2000-3B	Wire Spool 500' spool of 4-conductor 22-gauge wire
TIM-2000-3C	Wire Spool 500' spool of 8-conductor 22-gauge wire



TIM-AIR-BOX

TIRE INFLATION GAUGES & AIR CHUCKS



TIM-88



TIM-89



TIM-90

Inlet	1/4" NPT (F)	1/4" NPT (F)	1/4" NPT (F)
Description	Bayonet Tire Inflator Gauge With dual head	Deluxe Tire Inflator Gauge "Squeeze" trigger assembly simplifies tire filling. Unit has bleeder valve to allow quick adjustments for over pressurized tires, air gauge with protective cover, dual-head chuck and 12" hose. Pop-up gauge registers 0 to 140 PSI.	Dual Head Air Chuck For car and truck tires

LOW & MEDIUM PRESSURE SHUT-OFF VALVES

	TIM-250-BV	TIM-500-600	TIM-502-BV	TIM-752-BV	TIM-1001-BV	TIM-1501-BV
Inlet/Outlet	1/4"(F)	1/2"(F)	1/2"(F)	3/4"(F)	1"(F)	1-1/2"(F)
Working Pressure	400 PSI	600 PSI	2,000 PSI	2,000 PSI	600 PSI	600 PSI



TIM-1001-BV



TIM-502-BV

HIGH PRESSURE SHUT-OFF VALVES

High pressure carbon steel in-line needle valves for high pressure grease applications



TIM-500-HP1



TIM-500-HP2

Inlet/Outlet	1/2"(F) x 1/2"(F)	1/2"(M) x 1/2"(F)
Working Pressure	8,000 PSI	8,000 PSI

HIGH PRESSURE COUPLER & CONNECTOR

Ideal for high pressure grease applications. Used in lube truck applications for removing and storing the grease control handles. 10,000 PSI working pressure.



TIM-192

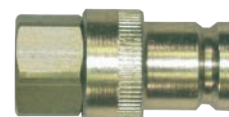

TIM-193

Thread Size	3/8"(F)	3/8"(F)
Type	Fluid Coupler	Fluid Connector

STEEL TUBING CONNECTORS

4,000 PSI (4:1 safety factor) 5/8" O.D. steel tubing compression fittings. May be used for either oil or grease.



SDB-10-TIM



SEB-10-TIM



SFB-10-TIM



SGB-10-TIM

Description	1/2"(F) x Tube	Tube x Tube	1/2"(M) x Tube	1/2"(F) x Tube
Type	90° Elbow	90° Elbow	Straight	Straight



SHB-10-TIM



SJB-10-TIM



SMB-10-TIM



SOB-10-TIM

Description	Tube x Tube	Tube x Tube x Tube	Tube x 1/2"(M) x Tube	Tube x 1/2"(F) x Tube
Type	Straight	Tee	Tee	Tee

STRAIGHT (M) X (F) UNION ADAPTERS

	(M) x (F)	Max PSI
TIM-1404-22	1/8" x 1/8"	10,000 PSI
TIM-1404-42	1/4" x 1/8"	10,000 PSI
TIM-1404-44	1/4" x 1/4"	10,000 PSI
TIM-1404-46	1/4" x 3/8"	7,000 PSI
TIM-1404-64	3/8" x 1/4"	7,000 PSI
TIM-1404-66	3/8" x 3/8"	7,000 PSI
TIM-1404-68	3/8" x 1/2"	7,000 PSI
TIM-1404-84	1/2" x 1/4"	7,000 PSI

	(M) x (F)	Max PSI
TIM-1404-86	1/2" x 3/8"	7,000 PSI
TIM-1404-88	1/2" x 1/2"	7,000 PSI
TIM-1404-128	3/4" x 1/2"	5,500 PSI
TIM-1404-812	1/2" x 3/4"	5,500 PSI
TIM-1404-1212	3/4" x 3/4"	5,500 PSI
TIM-1404-1216	3/4" x 1"	4,000 PSI
TIM-1404-1612	1" x 3/4"	4,000 PSI
TIM-1404-1616	1" x 1"	4,000 PSI

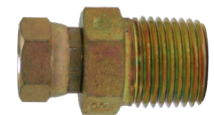

TIM-1404-84

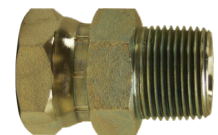

TIM-1404-1212

90°(M) X (F) UNION ADAPTERS

	(M) x (F)	Max PSI
TIM-1501-44	1/4" x 1/4"	10,000 PSI
TIM-1501-66	3/8" x 3/8"	7,000 PSI
TIM-1501-86	1/2" x 3/8"	7,000 PSI
TIM-1501-88	1/2" x 1/2"	7,000 PSI

	(M) x (F)	Max PSI
Y-43-4C*	1/2" x 1/2"	3,000 PSI
TIM-1501-1212	3/4" x 3/4"	5,500 PSI
TIM-1501-1616	1" x 1"	4,000 PSI



TIM-1501-88

* Non-swivel

STRAIGHT (F) X (F) UNION ADAPTERS

	(F) x (F)	Max PSI
TIM-1405-44	1/4" x 1/4"	10,000 PSI
TIM-1405-64	3/8" x 1/4"	7,000 PSI
TIM-1405-86	1/2" x 3/8"	7,000 PSI
TIM-1405-88	1/2" x 1/2"	7,000 PSI

	(F) x (F)	Max PSI
TIM-1405-128	3/4" x 1/2"	5,500 PSI
TIM-1405-1212	3/4" x 3/4"	5,500 PSI
TIM-1405-1616	1" x 1"	4,000 PSI



TIM-1405-88

45°(F) X (F) UNION ADAPTERS

	(F) x (F)	Max PSI
TIM-1504-44	1/4" x 1/4"	10,000 PSI
TIM-1504-66	3/8" x 3/8"	7,000 PSI

	(F) x (F)	Max PSI
TIM-1504-88	1/2" x 1/2"	4,000 PSI



TIM-1504-88

(M) X (M) ADAPTERS

	(M) x (M)	Max PSI
TIM-1200-1	1/8" x 1/8"	10,000 PSI
TIM-1201-1	1/8" x 1/4"	10,000 PSI
TIM-1202-1	1/8" x 3/8"	7,000 PSI
TIM-212-1	1/4" x 1/4"	10,000 PSI
TIM-1204-1	1/4" x 1/2"	7,000 PSI

	(M) x (M)	Max PSI
TIM-1205-1	3/8" x 3/8"	7,000 PSI
TIM-1206-1	3/8" x 1/2"	7,000 PSI
TIM-1208-1	1/2" x 3/4"	5,500 PSI
TIM-1210-1	3/4" x 1"	4,000 PSI
Y-27-54C	1/2" x 1/2"	7,000 PSI



TIM-1201-1



TIM-212-1

(M) X (F) ADAPTERS

	(M) x (F)	Max PSI
TIM-1220	1/8" x 1/4"	10,000 PSI
TIM-1221	1/8" x 3/8"	7,000 PSI
TIM-1222	1/8" x 1/2"	7,000 PSI
TIM-1223	1/4" x 3/8"	7,000 PSI

	(M) x (F)	Max PSI
TIM-1225	3/8" x 1/2"	7,000 PSI
TIM-1226	1/2" x 3/4"	5,500 PSI
TIM-1227	1/4" x 1/2"	7,000 PSI

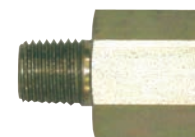

TIM-1223

(F) X (F) ADAPTERS

	(F) x (F)	Max PSI
TIM-1230	1/8" x 1/8"	10,000 PSI

	(F) x (F)	Max PSI
TIM-1263	1/2" x 1/2"	3,000 PSI



TIM-1263

REDUCING BUSHINGS

	(M) x (F)	Max PSI
TIM-1240	1/4" x 1/8"	10,000 PSI
TIM-1241	3/8" x 1/8"	7,000 PSI
TIM-1242	3/8" x 1/4"	7,000 PSI

	(M) x (F)	Max PSI
TIM-1243	1/2" x 1/8"	7,000 PSI
TIM-1244	1/2" x 1/4"	7,000 PSI
TIM-1245	1/2" x 3/8"	7,000 PSI



TIM-1245

AIR & WATER CONNECTING HOSE FOR PUMPS & REELS

	Hose ID	Thread Size	Hybrid Polymer Hose	Max PSI	Available Length (Feet)	For Use On
AIR-HP1414-____*	3/8"	1/4"(M) x 1/4"(M)	Yes	300 PSI	3, 5, 10	1/4" Air Connecting Hoses for Thunder Pumps, 1/2" & 1"
AIR-HP3812-2	3/8"	3/8"(M) x 1/2"(M)	Yes	300 PSI	2	3/8" Air/Water Reels
AIR-HP3838-____*	3/8"	3/8"(M) x 3/8"(M)	Yes	300 PSI	2, 4	3/8" Air/Water Reels
TIM-4218-2NS	1/2"	1/2"(M) x 1/2"-90° Swivel (M)	No	300 PSI	2	1/2" Air/Water Reels
TIM-4218-4NS	1/2"	1/2"(M) x 1/2"-90° Swivel (M)	No	300 PSI	4	1/2" Air/Water Reels
TIM-4218-5	1/2"	1/2"(M) x 1/2"(M)	No	300 PSI	5	1/2" Air Connecting Hose for AFX Series Pumps

* Add length of hose to the model number as the suffix. For example: **AIR-HP1414-5** is a 1/4" I.D. hose with 1/4"(M) ends by 5' long.

AIR & WATER DELIVERY HOSES FOR CONSOLES & REELS

	Hose ID	Thread Size	Hybrid Polymer Hose	Max PSI	Available Length (Feet)	For Use On
AIR-HP1414-15	3/8"	1/4"(M) x 1/4"(M)	Yes	300 PSI	15	Lube Consoles
AIR-HP3800-250	3/8"	Not Coupled	Yes	300 PSI	250' Spool	Air/Water Reels
AIR-HP3800-____*	3/8"	Not Coupled	Yes	300 PSI	250' Spool (can be cut to any length - call for pricing)	Air/Water Reels
AIR-HP3838-____*	3/8"	3/8"(M) x 3/8"(M)	Yes	300 PSI	50, 65	3/8" Air/Water Reels
TIM-4208-____*	1/2"	1/2"(M) x 1/2"(M)	No	300 PSI	50, 65, 75, 100	1/2" Air/Water Reels

* Add length of hose to the model number as the suffix. For example: **AIR-HP3838-50** is a 3/8" I.D. hose with 3/8"(M) ends by 50' long.

OIL CONNECTING HOSES FOR PUMPS & REELS

	Hose ID	Thread Size	Max PSI	Available Length (Feet)	For Use On
TIM-4418-_____*	1/2"	1/2"(M) x 1/2" 90° Swivel (M)	2,000 PSI	2NS, 2.5NS, 4NS	1/2" Oil Reels
TIM-4418-_____*	1/2"	1/2"(M) x 1/2" Swivel (M)	2,000 PSI	4S, 5S, 6S, 8S	1/2" Oil Reels
TIM-4412-_____*	3/4"	3/4"(M) x 3/4"(M)	1,250 PSI	3, 5	3/4" Oil Reels
TIM-4416-_____*	1"	1"(M) x 1"(M)	1,000 PSI	3, 5, 8, 10	1" Oil Reels
628067-3	1"	1"NPT x 1"NPT	150 PSI	3	Waste Oil Evacuation System (612999-4)

* Add length of hose to the model number as the suffix. For example: **TIM-4418-5S** is a 1/2" I.D. hose with 1/2"(M) ends by 5' long.

OIL DELIVERY HOSES FOR CONSOLES & REELS

	Hose ID	Thread Size	Max PSI	Available Length (Feet)	For Use On
TIM-4418-_____*	1/2"	1/2"(M) x 1/2"(M)	2,000 PSI	15, 18, 40	1/2" Oil Reels & Quick-Lube Consoles
TIM-4418-_____*	1/2"	1/2"(M) x 1/2" Swivel (M)	2,000 PSI	10S, 16S, 18S, 20S, 25S, 30S, 50S, 75S, 100S	1/2" Oil Reels & Quick-Lube Consoles
TIM-4412-_____*	3/4"	3/4"(M) x 3/4"(M)	1,250 PSI	15, 30, 50	3/4" Oil Reels
TIM-4416-_____*	1"	1"(M) x 1"(M)	1,000 PSI	15, 30	1" Oil Reels

* Add length of hose to the model number as the suffix. For example: **TIM-4418-10** is a 1/2" I.D. hose with 1/2"(M) ends by 10' long.

GREASE CONNECTING HOSES FOR PUMPS & REELS

	Hose ID	Thread Sizes	Max PSI	Available Length (Feet)	For Use On
TIM-4516-2NS	3/8"	3/8"(M) x 3/8"-90° Swivel (M)	4,000 PSI	2	3/8" Grease Reels
TIM-4516-4NS	3/8"	3/8"(M) x 3/8"-90° Swivel (M)	4,000 PSI	4	3/8" Grease Reels
TIM-4516-____*	3/8"	3/8"(M) x 3/8"(M)	4,000 PSI	2, 4, 8	ARO Grease Pumps & 3/8" Grease Reels

* Add length of hose to the model number as the suffix. For example: **TIM-4516-8** is a 3/8" I.D. hose with 3/8"(M) ends by 8' long.

GREASE DELIVERY HOSES FOR CONSOLES & REELS

	Hose ID	Thread Sizes	Max PSI	Available Length (Feet)	For Use On
TIM-4515-5	1/4"	1/8"(M) x 1/8"(M)	5,000 PSI	5	TIM-83-KM Pump
TIM-4514-____*	1/4"	3/8"(M) x 1/4"(M)	4,000 PSI	10, 20, 30	Portable Grease Pumps
TIM-4506-____*	3/8"	3/8"(M) x 3/8"-90° Swivel (M)	4,000 PSI	15, 100	3/8" Grease Reels
TIM-4506-____*	3/8"	3/8"(M) x 3/8"-90° Swivel (M)	4,000 PSI	25S, 50S, 65S, 75S	3/8" Grease Reels

* Add length of hose to the model number as the suffix. For example: **TIM-4506-50S** is a 3/8" I.D. hose with 3/8"(M) ends by 50' long.

HAND-OPERATED GREASE GUNS



4120

Industrial Hi-Flow Heavy-Duty Grease Gun

Generates 10,000 PSI, cast aluminum pump head. Delivers 1 ounce in 9 strokes twice the volume per stroke when compared to the best variable stroke guns, 3-way loader capability (loader fitting included). Full pressure on variable or short strokes for controlled grease output and easy operation in tight quarters. Comes with rugged plastic handle grip, loader fitting, air release valve, heavy-duty hydraulic coupler with ball check and rigid extension.

For case quantities order part number 4120-10



NEW

4121

Heavy-Duty Grease Gun

10,000 PSI rated heavy-duty grease gun with 18" whip hose. For standard 14-1/2 oz cartridge. Equipped with hydraulic coupler and rigid extension.

For case quantities order part number 4121-10



4127

Suction Gun

Suction gun with 11" vinyl hose. Low friction o-ring for positive sealing. Pumps approximately one (1) pint of non-corrosive liquid per stroke.



4130

Deluxe Heavy-Duty Pistol Grip Grease Gun

6,000 PSI rated. Gun features unique 2-outlet port design which allows the hose or rigid extension to be mounted on the side or the top of the grease gun head. Aluminum head, 3-way loader capability (loader fitting included). Takes standard 14-1/2 ounce cartridge and has a 16 ounce bulk fill capacity. Gun comes with loader fitting, air release valve, hydraulic coupler with ball check and rigid extension. Packaged in a 4-color POP box. Compare to Alemite 525 & Lincoln 1132.

For case quantities order part number 4130-10



4131

Deluxe Heavy-Duty Pistol Grip Grease Gun with 18" Hose

Same as 4130 but also includes TIM-4321 18" rubber flex hose. Packaged in a 4-color POP box. Compare to Alemite 550 & Lincoln 1133.

For case quantities order part number 4131-10

HAND GREASE GUN WHIP HOSES

TIM-4320	12" Whip Hose 12" rubber flex hose. Coupled 1/8" NPT (M). 3,000 PSI maximum working pressure. Working temperature is -50°C~+150°C (-58°~+302°F).
TIM-4320-S	12" Whip Hose 12" flex hose. Coupled 1/8" NPT (M). Comes in clear clamshell display board packaging. 3,000 PSI maximum working pressure.
TIM-4320-TP	12" Whip Hose 12" standard duty thermoplastic hose for hand-operated grease guns. Coupled 1/8" NPT (M). 3,000 PSI maximum working pressure.
TIM-4321	18" Whip Hose 18" rubber flex hose. Coupled 1/8" NPT (M). 3,000 PSI maximum working pressure. 12,000 PSI burst pressure. Working temperature is -50°C~+150°C (-58°~+302°F).
TIM-4321-S	18" Whip Hose 18" rubber hose. Coupled 1/8" NPT (M). Comes in clear clamshell display board packaging. 3,000 PSI maximum working pressure.
TIM-4321-TP	18" Whip Hose 18" standard duty thermoplastic hose for hand-operated grease guns. Coupled 1/8" NPT (M). 3,000 PSI maximum working pressure.
TIM-4322	24" Whip Hose 24" rubber flex hose. Coupled 1/8" NPT (M). 3,000 PSI maximum working pressure.
TIM-4323	36" Whip Hose 36" rubber flex hose. Coupled 1/8" NPT (M). 3,000 PSI maximum working pressure.



TIM-4320

WARNING: For use on hand grease guns only. Do not use with air operated equipment.

HAND GREASE GUN WHIP HOSE ASSEMBLIES

TIM-4340	12" Whip Hose Assembly with Narrow Diameter Coupler (TIM-100) Coupled 1/8" NPT (M). 3,000 PSI maximum working pressure.
TIM-4341	18" Whip Hose Assembly with Narrow Diameter Coupler (TIM-100) Coupled 1/8" NPT (M). 3,000 PSI maximum working pressure.
TIM-4342	12" Whip Hose Assembly with Standard Diameter Coupler (TIM-101) Coupled 1/8" NPT (M). 3,000 PSI maximum working pressure.
TIM-4343	18" Whip Hose Assembly with Standard Diameter Coupler (TIM-101) Coupled 1/8" NPT (M). 3,000 PSI maximum working pressure.

WARNING: For use on hand grease guns only. Do not use with air operated equipment.



TIM-4340

HYDRAULIC & BUTTONHEAD GREASE COUPLERS



	TIM-100*	TIM-101**	TIM-106
Size	Narrow Diameter	Standard Diameter	Standard Buttonhead
Thread Size	1/8"(F)	1/8"(F)	1/8"(F)
Type	Ball Check	Ball Check	Pull On
Max PSI	10,000 PSI	20,000 PSI	4,000 PSI

* These couplers available in 25, 50 and 200 count packs

** These couplers available in 25 and 50 count packs

HYDRAULIC GREASE ADAPTERS



TIM-126-1

High-Pressure Needle Point Grease Adapter

Connects to grease coupler via included locking sleeve adapter. Overall length 5-1/2". 10,000 PSI maximum working pressure.



4412

"Push-On" Grease Fitting Adapter

Allows for easy greasing of standard grease fittings where access is limited or in low-height areas. Connects to grease coupler via included locking sleeve adapter.

WARNING: For use on hand-operated grease guns only

GREASE FITTINGS

American Lubrication fittings are sold in clamshell display packs of 10 pieces and bags of 100 pieces. American Lubrication has one of the largest standing inventories of U.S. thread, metric thread, thread-forming, drive and stainless steel grease fittings. Our extensive offering of fittings covers virtually every automotive, agricultural, industrial, marine and lawn and garden application.

For fittings not listed please call American Lubrication

1/8" PTF GREASE FITTINGS



	18-001*	18-002	18-003*	18-004	18-030	18-045*	18-065*	18-090*
Type	Straight	Straight	Straight	Straight	30°	45°	65°	90°
Thread Size	1/8"	1/8"(F)	1/8"	1/8"	1/8"	1/8"	1/8"	1/8"
Length	.62"	1.00"	1.25"	1.77"	.91"	.98"	.88"	.82"

1/4"-28 GREASE FITTINGS



	14-28001*	14-28002	14-28003	14-28004
Type	Straight	Straight	Straight	Straight
Thread Size	1/4"-28	1/4"-28	1/4"-28	1/4"-28
Length	.54"	.69"	.93"	1.08"



	14-28045	14-28046	14-28090*	14-28UNF
Type	45°	45°	90°	Straight
Thread Size	1/4"-28	1/4"-28	1/4"-28	1/4"-28 UNF
Length	.88"	.97"	.69"	.49"

1/4" PTF GREASE FITTINGS



	14-001*	14-067*
Type	Straight	67-1/2°
Thread Size	1/4"	1/4"
Length	.80"	.96"

SPECIAL THREAD GREASE FITTINGS



	T-7504	T-7505
Type	Straight	Straight
Thread Size	5/16"-24 UNF	3/8"-24 UNF
Length	.62"	.62"

Fittings must be purchased in quantities of 100

* These fittings available in 10 packs

STAINLESS STEEL GREASE FITTINGS

Stainless steel grease fittings are designed to be used in harsh and highly corrosive environments. Stainless steel grease fittings use 303 stainless steel on the body and head, stainless steel stress relieving spring and a stainless steel ball. All stainless steel fittings have a single notch identification mark on the hexagonal corners.



777-142801



777-142845



777-142890*



777-1801*



777-1845*

Type	Straight	45°	90°	Straight	45°
Thread Size	1/4"-28	1/4"-28	1/4"-28	1/8"	1/8"
Length	.54"	.88"	.69"	.62"	.99"



777-1890*



777-1401



777-DR14



777-DR316

Type	90°	Straight	Straight	Straight
Thread Size	1/8"	1/4"	1/4" Drive	3/16" Drive
Length	.82"	.82"	.5"	.5"

* This fitting available in 10 packs

METRIC THREAD GREASE FITTINGS



M6-001



M6-045*



M6-090*



M8-001



M8-045

Type	Straight	45°	90°	Straight	45°
Thread Size	M6 x 1	M6 x 1	M6 x 1	M8 x 1	M8 x 1
Length	.53"	.89"	.71"	.59"	.88"



M8-090



M10-001*



M10-045*



M10-090*

Type	90°	Straight	45°	90°
Thread Size	M8 x 1	M10 x 1	M10 x 1	M10 x 1
Length	.70"	.60"	.93"	.75"

* This fitting available in 10 packs

THREAD FORMING GREASE FITTINGS

Thread forming fittings have special hardened threads which allow the fitting to be screwed into a drilled hole which eliminates having to tap the hole. When installed, they force a rearrangement of the metal to conform with their own thread design, which is leak tight and permanent. They can easily be replaced by another thread forming fitting or standard fitting. All thread forming fittings have a yellow zinc finish and can withstand a 70-hour salt spray test.



T-7302



T-7303



T-7305



T-7307

Type	90°	Straight	90°	45°
Thread Size	1/8"	1/4"	1/4"-28	1/4"-28
Length	.69"	.56"	.68"	.78"

DRIVE TYPE GREASE FITTINGS

Drive type fittings are most commonly used in high volume installations to avoid tapping costs. The serrated shank holds the fitting securely in place when driven into a hole. All drive fittings have a yellow zinc finish and can withstand a 70-hour salt spray test.

Actual drill size may depend upon the nature of the material into which the fitting is driven



T-7603*



DR-316-NB2*



DR-316



DR-316-NB*

Type	Straight	Straight	Straight	Straight
Thread Size	3/16"	3/16"	3/16"	3/16"
Length	.47"	.49"	.50"	.50"



DR-14-NB*



DR-14



DR-516



T-7604

Type	Straight	Straight	Straight	Straight
Thread Size	1/4"	1/4"	5/16"	3/16"
Length	.41"	.50"	.58"	.49"



T-7614



T-7615



T-7616



T-7619*

Type	65°	Straight	Straight	Straight
Thread Size	1/4"	6MM	8MM	1/8"
Length	.85"	.57"	.61"	.47"

* This fitting has no ball check

BUTTONHEAD GREASE FITTINGS

All buttonhead fittings are straight fittings with a maximum pressure rating of 6,000 PSI. Standard buttonhead fittings are 5/8" diameter.



BH-18



BH-14



BH-38

Type	Standard	Standard	Standard
Thread Size	1/8"	1/4"	3/8"
Length	.76"	.83"	.98"

VENTED, RELIEF & LEAKPROOF SPECIALTY FITTINGS

Relief fittings are designed to open at pre-determined pressures

Leakproof fittings are equipped with a rubber seal instead of a ball check for use with light oils and heavy lubricants. Leakproof fittings are designed to handle up to 5,000 PSI of back pressure.



T-7040



T-7046



T-7048



T-7700

Type	Vented	Relief	Relief	Leakproof
Relief Min	—	1 PSI	1 PSI	—
Relief Max	—	5 PSI	5 PSI	—
Thread Size	1/8" †	1/8"	1/8"	1/8"
Length	.66"	.47"	.50"	.85"

† Thread is 1/8" PTF-SAE short

110-PIECE STANDARD FITTING ASSORTMENT



4450

110-Piece Standard Grease Fitting Assortment

Includes forty (40) 14-28001, ten (10) 14-28045, ten (10) 14-28090, twenty (20) 18-001, ten (10) 18-045, ten (10) 18-065, and ten (10) 18-090

110-PIECE METRIC FITTING ASSORTMENT



4451

110-Piece Metric Grease Fitting Assortment

Includes forty (40) M6-001, five (5) M6-045, five (5) M6-090, twenty (20) M8-001, five (5) M8-045, five (5) M8-090, twenty (20) M10-001, five (5) M10-045, and five (5) M10-090

55-PIECE STAINLESS STEEL FITTING ASSORTMENT



4452

55-Piece Stainless Steel Grease Fitting Assortment

Includes twenty (20) 777-142801, five (5) 777-142845, five (5) 777-142890, ten (10) 777-1801, five (5) 777-1845, five (5) 777-1890, and five (5) 777-1401

GREASE FITTING EXTRACTOR & RE-THREADING & THREAD TESTER TOOLS

4455	Thread tester
TIM-151	Extractor & Re-Threading Tool Used for replacing broken 1/4"-28 grease fittings
TIM-152	Extractor & Re-Threading Tool Used for replacing broken 1/8"-27 pipe thread grease fittings. PTF fittings are sometimes generically referred to as 1/8" NPT.



TIM-151



TIM-152

ELECTRIC PUMP PACKAGES



DEF3-TM49N
(tote and dispense coupler not included)

PUMP TECHNICAL SPECIFICATIONS

	120-Volts	12-Volts
Working Flow Rate	9 GPM	9 GPM
Max Fluid Pressure	50 PSI	50 PSI
Watts	400	260
RPM	1400	2800
Voltage	110V/60Hz	12V
Timer	6.5 Minutes	—

ALL KITS INCLUDES:

- DEF Pump
- 4' Suction Hose
- 20' Delivery Hose
- Hose Tails & Clamps
- Mounting Bracket

120-VOLT TOTE SYSTEMS

	Nozzle	Meter	Mounting Bracket	Dispense Coupler
DEF3-TM49C	DEF-49	DEF-22	DEF3-BKT	DEF-34PL
DEF3-TM49E	DEF-49	DEF-22	DEF3-BKT	DEF-39
DEF3-TM49N	DEF-49	DEF-22	DEF3-BKT	—
DEF3-TM49S	DEF-49	DEF-22	DEF3-BKT	DEF-34A
DEF3-TM50N	DEF-50	DEF-22	DEF3-BKT	—
DEF3-TM50S	DEF-50	DEF-22	DEF3-BKT	DEF-34A
DEF3-TM57N	DEF-49	DEF-22	DEF3-BKT	—
DEF3-TN49N	DEF-49	—	DEF3-BKT	—
DEF3-TN49S	DEF-49	—	DEF3-BKT	DEF-34A
DEF3-TN50C	DEF-50	—	DEF3-BKT	DEF-34PL
DEF3-TN50N	DEF-50	—	DEF3-BKT	—
DEF3-TN58S	DEF-58	—	DEF3-BKT	DEF-34A

120-VOLT PORTABLE SYSTEMS (55-GALLON DRUM)

	Nozzle	Meter	Mounting Bracket	Heavy-Duty Cart
DEF3-TM49N4	DEF-49	DEF-22	DEF3-BKT	TIM-401
DEF3-TM50N4	DEF-50	DEF-22	DEF3-BKT	TIM-401
DEF3-TN50N4	DEF-50	—	DEF3-BKT	TIM-401

120-VOLT STATIONARY SYSTEMS (55-GALLON DRUM)

	Nozzle	Meter	Mounting Bracket
DEF3-DN49N	DEF-49	—	DEF2-BKT
DEF3-DN50N	DEF-50	—	DEF2-BKT

12-VOLT TOTE SYSTEMS

	Nozzle	Meter	Mounting Bracket	Dispense Coupler
DEF6-TM49C	DEF-49	DEF-22	DEF3-BKT	DEF-34PL
DEF6-TM49E	DEF-49	DEF-22	DEF3-BKT	DEF-39
DEF6-TM49N	DEF-49	DEF-22	DEF3-BKT	—
DEF6-TM49S	DEF-49	DEF-22	DEF3-BKT	DEF-34A
DEF6-TN49N	DEF-49	—	DEF3-BKT	—
DEF6-TN50C	DEF-50	—	DEF3-BKT	DEF-34PL
DEF6-TN50N	DEF-50	—	DEF3-BKT	—

12-VOLT PORTABLE SYSTEMS (55-GALLON DRUM)

	Nozzle	Meter	Mounting Bracket	Heavy-Duty Cart
DEF6-TM49N4	DEF-49	DEF-22	DEF3-BKT	TIM-401

12-VOLT STATIONARY SYSTEMS (55-GALLON DRUM)

	Nozzle	Meter	Mounting Bracket
DEF6-DM49N	DEF-49	DEF-22	DEF2-BKT
DEF6-DN50N	DEF-50	—	DEF2-BKT



DEF3-TM49N4
(drum and dispense coupler
not included)



DEF3-TN50N
(tote and dispense coupler not included)



DEF6-DM49N
(drum and dispense coupler not included)

AIR-OPERATED PUMP PACKAGES



DEF-11
(tote and dispense coupler not included)

PUMP TECHNICAL SPECIFICATIONS

	ARO PD07P-APS-PAA
Max Flow Rate	14.8 gpm
Working Flow Rate	6-7 GPM
Air Operating Range	30-50 PSI
Max Fluid Pressure	50 PSI
Air Inlet/Outlet (F)	1/4" NPT
Pump Inlet	3/4" NPT

ALL KITS INCLUDES:

- ARO PD07P-APS-PAA 3/4" Diaphragm Pump
- ARO P-39224-624 Filter/Regulator
- 4' Suction Hose
- 20' Delivery Hose
- Hose Tails & Clamps
- Mounting Bracket

TOTE MOUNT

	Nozzle	Nozzle with Meter	Mounting Bracket	Heavy Duty Cart
DEF-10	—	DEF-58	TIM-463	—
DEF-11	DEF-49	—	TIM-463	—

PORTABLE

	Nozzle	Nozzle with Meter	Mounting Bracket	Heavy Duty Cart
DEF-12	—	DEF-58	TIM-463	TIM-401
DEF-13	DEF-49	—	TIM-463	TIM-401

ECONOMICAL DEF PUMP

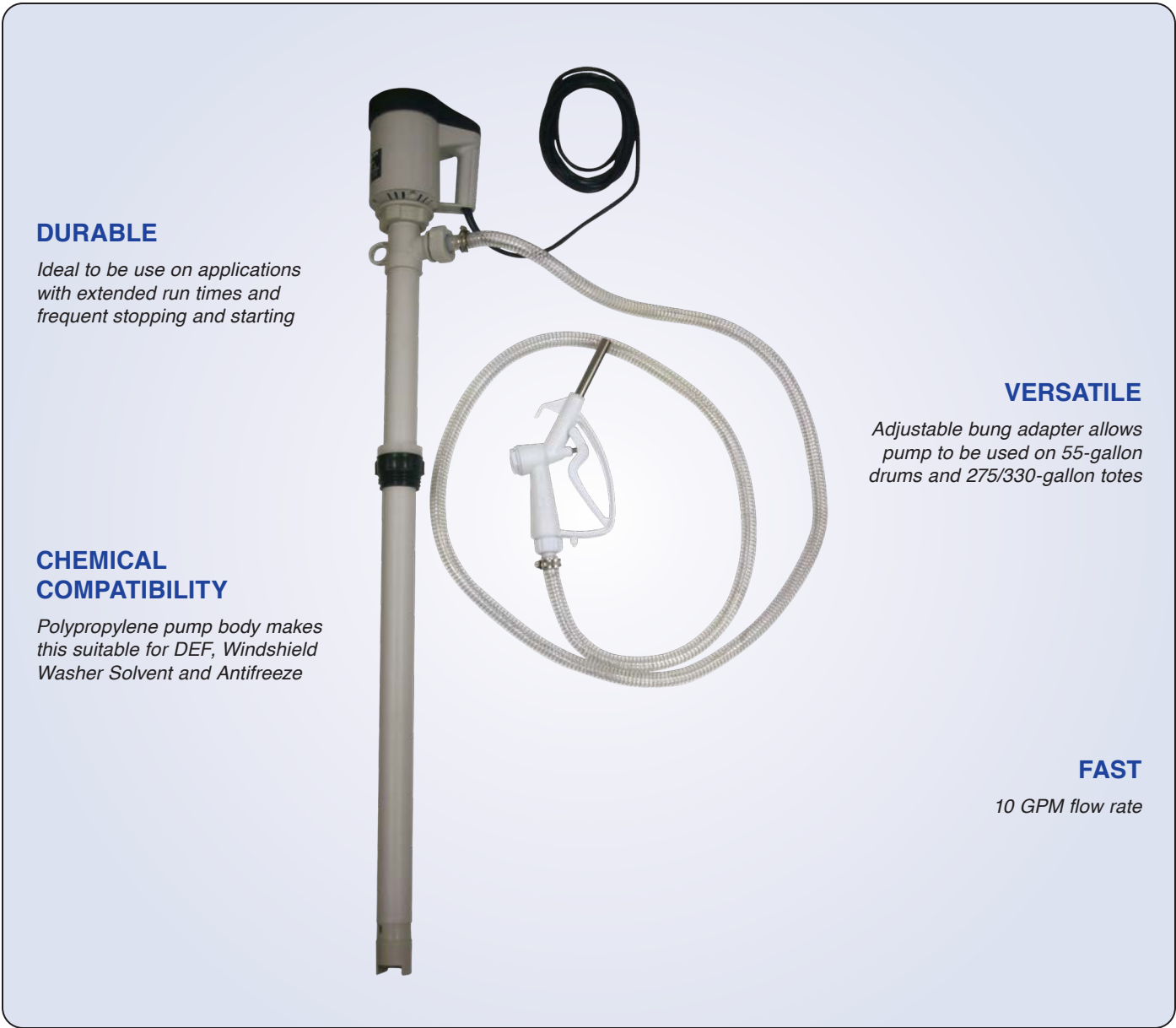

DURABLE

Ideal to be use on applications with extended run times and frequent stopping and starting

CHEMICAL COMPATIBILITY

Polypropylene pump body makes this suitable for DEF, Windshield Washer Solvent and Antifreeze

VERSATILE

Adjustable bung adapter allows pump to be used on 55-gallon drums and 275/330-gallon totes

FAST

10 GPM flow rate

SPECIFICATIONS

DEF-1000

Flow Rate	10 GPM
Fluid Outlet Size	3/4" barb
Tube Length	48"
Handle Material	Polythlene
Working Pressure	7 PSI
Tube Diameter	2"
Voltage	110-Volts
Adapter	2.5 x 5 Buttress/ 2" NPT
Hose	9.8'
Used On	55-Gallon Drums, 275/330-Gallon Totes & Container up to 45" in Depth

FLUID COMPATIBILITY



Antifreeze



DEF



Windshield Washer Fluid

BARE ELECTRIC PUMPS

DEF3A-PUMP

120-Volt Pump with Timer

Includes 6' electric cord and two (2) 3/4" hose barb connectors. 120VAC, 60HZ, 500W, 1730 RPM, 7 GPM, 23 PSI.

Illuminated switch. Seven (7) minute timer protects pump and motor (cycle power to reset).



DEF3A-PUMP

DEF6-PUMP

12-Volt Electric Pump

Includes only 6' cables. 2,800 RPM, 18 amp, 7-9 GPM and 3/4" barbed inlet/outlet.

NOTE: Power switch does not light when ON. Pump is not equipped with a timer circuit.

DIAPHRAGM PUMPS

	Body	Ball	Diaphragm & O-Ring	Air Inlet (F)	Inlet/Outlet	Max PSI	GPM Max
PD07P-APS-PAA	Polypropylene	Santoprene	Santoprene	1/4"	3/4"	100 PSI	14.8 GPM
PD10P-APS-PAA	Polypropylene	Santoprene	Santoprene	1/4"	1"	120 PSI	53 GPM



PD07P-APS-PAA



PD10P-APS-PAA

HAND-OPERATED DRUM PUMPS



4166-DEFN



DEF-100AS



DEF-100AH

Container Size	55-Gallon Drums	55-Gallon Drums	55-Gallon Drums
Fluid Compatibility	DEF	DEF	DEF
Downtube Type	Polypropylene	Polypropylene	Polypropylene
Body Material	Polypropylene with Teflon® Seals	Polypropylene with Teflon® Seals	Polypropylene with Teflon® Seals
Pump Type	Rotary	Lever (piston)	Lever (piston)
Delivery	8 Ounces per Revolution	1 Gallon per 10 Strokes	1 Gallon per 10 Strokes
Nozzle	Manual Nozzle	Stainless Steel Spout	Manual Nozzle
Hose Length	9.8'	9.8'	9.8'

HOSE REEL

DEF-52H33S

Hose Size	3/4"
Hose Length	33'
Hose Stop	Included
Inlet/Outlet	3/4" barb inlet / 3/4" hose outlet
Max PSI	150 PSI
Weight	53 lbs



DEF-52H33S

METER



DEF-22

Electronic DEF Meter

1.3 to 26 gallon/minute flow rate. 145 PSI operating pressure. 1" BSPP (M) inlet/outlet, includes stainless steel 1" BSPP (F) x 1" BSPP (F) coupler. Directional (marked). Power Supply: 2x1.5 V alkaline batteries size AAA.

CONTROL HANDLES



DEF-49

Stainless Steel Automatic Nozzle
(3/4" barb inlet)



DEF-50

Polyethylene Manual Nozzle
(3/4" barb inlet)



DEF-57

Polyethylene Automatic Nozzle
with magnetic mis-filling prevention adapter
(3/4" barb inlet)



DEF-58

Polyethylene Automatic Nozzle
with built-in digital meter
(3/4" barb inlet)

CONTROL HANDLE ACCESSORIES



DEF-57DA

Replacement magnetic mis-filling prevention adapter for DEF-57 and DEF-495



DEF-49-SWIVEL

3/4"(M) Swivel
(for DEF-49 only)

4-PIN REUSABLE COUPLERS & DOWNTUBES

DEF-34A	Stainless Steel Dispense Coupler with 3/4" barbed outlet - 4 pin
DEF-34PL	Composite Dispense Coupler with 3/4" barbed outlet - 4 pin
DEF-40A	Stainless Steel Container Valve 4 pin
DEF-40PL	Composite Container Valve 4 pin
DEF-41	Tool for DEF-40PL Container Valve
DEF-54	Vapor Recovery Fill Head Coupler Inlet threads, 1" -11-1/2 NPT (M), Vapor recovery outlet threads, 1/4"-18 NPT (F)
DEF-TUBE55	Downtube for DEF-40A, DEF-40PL (55" L x 1" ID) Cut to length. Suitable for drums and totes.

Uses 22mm downtube



DEF-34A



DEF-34PL



DEF-54



DEF-40A

3-PIN COUPLERS & DOWNTUBES

DEF-39	Dispense Coupler 3/4" barbed outlet - stainless steel, 3 pin, multiple use
DEF-42	Container Valve composite, 3 pin
DEF-43	Downtube for 55-Gallon Drum 31.5" length
DEF-44	Downtube for 275-Gallon IBC 44" length
DEF-45	Downtube for 330-Gallon IBC 46" length
DEF-73	Install/Removal Tool

Uses 17mm downtube



DEF-40PL



DEF-39



DEF-42

MOUNTING BRACKETS

DEF2-BKT	Drum Mounting Bracket for Electric DEF Pumps
DEF3-BKT	Tote-Mounting Bracket for Electric DEF Pumps
TIM-463	IBC Tote Bracket for 1/2" & 3/4" ARO Diaphragm Pumps & Electric DEF Pumps



TIM-463

ADAPTERS

4190	Nylon Buttress Thread Adapter 2" NPT (F) x 2.5 x 5 buttress (M). Converts buttress thread to 2" NPT
DEF-55	Plastic Hose Tail Fitting 3/4" barb x 1" BSP (F)
DEF-74	Plastic Hose Tail Fitting 3/4" barb x 1" BSP (M)
DEF-75	Plastic Fitting 90° socket 3/4" barb x 1" BSP (F)
DEF-75BT	Plastic Fitting 3/4" NPT x 3/4" barb
DEF-76	Plastic Fitting 90° socket 1" BSP (F) x 1" BSP (F)
DEF-78	Plastic Fitting 1" BSP (M) with ring nut and nipple x 3/4" barb
DEF-80	Plastic Fitting 1" BSP (F) x 1" BSP (F)
DEF-81	Plastic Fitting 3/4" BSP (M) x 1" BSP (F) (for auto nozzle)



DEF-55



DEF-80



4190

ACCESSORIES

DEF-25A	Adapter Kit for DEF-22 Meter with Manual Nozzle
DEF-31	3/4" ID Delivery Hose (Per Foot)
DEF-32	3/4" ID Suction Hose (Per Foot)
DEF-51A	Stainless Steel Hose Clamps for 3/4" Hose (Two [2] Each)
DEF-53A	Adapter Kit for DEF-22 Meter with Automatic Nozzle
DEF-69	6" Center Mount Cap with one (1) 2.5 x 5 Buttress Thread Opening
DEF-69-2	6" Tote Cap with two (2) 2.5 x 5 Buttress Thread Openings
DEF-70	Shipping Cap
DEF-71	Dust Cover
DEF-72	Tamper Wire



DEF-51A



DEF-69

AMERICAN LUBRICATION LIMITED WARRANTY

American Lubrication Equipment Corporation (ALEC) warrants to the original use purchaser for the original installation of the products depicted in this catalog. Warranty claims involving travel time and labor must be pre-approved by American Lubrication Equipment Corporation's service department. ALEC does not pay travel time to repair/replace control handles, air systems components or portable equipment.

ALEC PRODUCTS

ALEC, at its option, will repair or replace, free of charge, any product (excluding Advantage Plus and Challenger Series products) manufactured by ALEC that under normal use and service proves defective in material or workmanship, as determined by ALEC upon inspection within one year from date of purchase, 90 days from date of purchase if product is an air hose, two years from date of purchase if the product is an ESQ Series electric oil pump, DEF pump or three years from date of purchase if the product is an Electronic Digital Meter (excluding batteries) or Electronic Digital Metered Control Handle (excluding batteries), provided the product or part claimed to be defective is returned promptly to the ALEC facility or ALEC authorized service center with transportation charges prepaid, and is accompanied by original proof of purchase. This limited warranty does not cover failure of parts or components due to normal wear or damage or wear that in the judgement of ALEC results from misuse, abrasion, corrosion, negligence, accident, substitution of a non-ALEC part, faulty installation or tampering. If ALEC's inspection discloses no defect in material or workmanship, ALEC will notify the purchaser and, upon authorization by the purchaser, ALEC will repair or replace and return the product at ALEC's customary charges.

ADVANTAGE PLUS PRODUCTS

ALEC will provide repair parts free of charge for any Advantage Plus product that under normal use and service proves defective in material or workmanship, as determined by ALEC upon inspection within five years from date of purchase, provided the part claimed to be defective is returned promptly to ALEC with transportation charges prepaid, and is accompanied by original proof of purchase.

During the first year, ALEC, at its option, will repair or replace, free of charge, any Advantage Plus product, that under normal use and service proves defective in material or workmanship, as determined by ALEC upon inspection within one year from date of purchase, provided the product or part claimed to be defective is returned promptly to ALEC or an ALEC authorized service center with transportation charges prepaid, and is accompanied by original proof of purchase. This limited warranty does not cover failure of parts or components due to normal wear or damage or wear that in the judgment of ALEC results from misuse, abrasion, corrosion, negligence, accident, substitution of a non-ALEC part, faulty installation or tampering. If ALEC's inspection discloses no defect in material or workmanship, ALEC will notify the purchaser and, upon authorization by the purchaser, ALEC will repair or replace and return the product at ALEC's customary charges.

The Advantage Plus Products 5-Year Limited Warranty does not cover routine maintenance, including but not limited to, normal user performed adjustments and maintenance of equipment, and the adjustment of any field adjustable packing nuts.

PRODUCTS NOT MANUFACTURED BY ALEC

ALEC makes no warranty as to products, accessories or components not manufactured by ALEC. These are subject to the warranty, if any, of their manufacturer. ALEC will provide reasonable assistance to the purchaser in making such claims.

NOTICE

The foregoing limited warranty supersedes, voids and is in lieu of any and all other warranties, expressed or implied. ALEC makes no warranty of merchantability or fitness for a particular purpose. ALEC's sole obligation and the original use purchaser's sole remedy is as stated above, and in no event shall ALEC be liable for any special, direct, indirect, incidental, consequential or other damages or expenses of any nature including, without limitation, loss of profits or production time incurred by the original use purchaser or any other party.

ARO LUBRICATION EQUIPMENT WARRANTY

Ingersoll-Rand Fluid Products ("IRFP") warrants to the original use purchaser of the ARO® products depicted in this catalog that IRFP will repair or replace, free of charges, including return shipping costs within the Continental United States of America, any such product which under normal use and service proves defective in material and workmanship, as determined by IRFP inspection, within (A) 1 year from date of purchase of said products, other than the following, (B) 5 years from date of purchase of a Thunder Series Pump, (C) 5 years from date of purchase of a Diaphragm Pump, and (D) 5 years from date of purchase ARO® manufactured swivels, non-metered control handles, 4-1/4", 6" pumps, drains, follower plates, tie downs, siphon tubes, drum covers, provided the claimed defective product, or part thereof, is promptly returned to the IRFP factory or IRFP Customer Service Center with transportation charges prepaid.

This warranty does not cover failure of parts or components due to normal wear or damage or wear which in the judgement of ARO® arises from misuse, abrasion, corrosion, negligence, accident, substitution of non-ARO parts, faulty installation or tampering.

If IRFP inspection discloses no defect in material or workmanship, repair or replacement and return will be made at customary charges.

Equipment not covered by IRFP warranty: Accessories or components of equipment sold by IRFP that are not manufactured by IRFP (such as switches, hoses, meters, etc.) are subject to the warranty, if any, of their manufacturer. IRFP will provide the purchaser with reasonable assistance in making such claims.

The foregoing warranty supersedes, voids and is in lieu of all or any other warranties, expressed or implied, and no warranty of merchantability or fitness for particular purpose is intended or made. IRFP's sole obligation and the original use purchaser's sole remedy is as stated above and in no event shall IRFP be liable for any special, direct, indirect, incidental, consequential or other damages or expenses of any nature including, without limitation, loss of profits or production time incurred by the original use purchaser or any other party.

ARO AIR SYSTEMS COMPONENTS WARRANTY

Ingersoll-Rand Fluid Products ("IRFP") warrants to the original use purchaser of the ARO® Air Systems Components depicted in this catalog that IRFP will repair or replace, free of charges, including return shipping costs within the Continental United States of America, any such product which under normal use and service proves defective in material or workmanship, as determined by IRFP inspection, two years from date of purchase, provided the claimed defective product or part thereof, is promptly returned to the IRFP Service Repair Center or a factory-authorized service repair center, with transportation charges prepaid.

If IRFP inspection discloses no defect in material or workmanship, repair or replacement and return will be made at customary charges.

The foregoing warranty supersedes, voids and is in lieu of all or any other warranties, expressed or implied, and no warranty of merchantability or fitness for particular purpose is intended or made. IRFP's sole obligation and the original use purchaser's sole remedy is as stated above and in no event shall IRFP be liable for any special, direct, indirect, incidental, consequential or other damages or expenses of any nature including, without limitation, loss of profits or production time incurred by the original use purchaser or any other party.

AMERICAN LUBRICATION POLICY

RETURNS: No returns will be accepted without prior written authorization from American Lubrication

Equipment Corporation. All items to be returned must be in the original factory carton and must be in unused re-saleable condition with transportation charges prepaid. All returned goods will be subject to inspection by American Lubrication Equipment Corporation before credit is issued. We reserve the right to charge an additional handling fee or return items to the purchaser if products are found to be in unacceptable condition upon our inspection. Customer must supply a copy of our original invoice as proof of purchase.

STOCK ADJUSTMENT: Stock adjustments will be made with prior written authorization. A list including quantities and model numbers of items to be returned must be faxed or mailed to American Lubrication Equipment Corporation.

Only active part numbers will be considered and the products must have been purchased within the last 18 months. A 15% handling charge will be assessed. The 15% handling charge will be waived if a 2:1 offsetting order accompanies the original request for stock adjustment.

WARRANTY: Warranty claims will be handled in accordance with the written warranties found in the Ingersoll-Rand ARO Fluid Products catalog and the American Lubrication Equipment Corporation lubrication equipment and supplies catalog. Contact either American Lubrication Equipment Corporation or one of our authorized warranty service centers with warranty claims.

DEFECTIVE ITEM(S): Prior written authorization is required in order to return items that are defective. Fax or mail your request for authorization for return to American Lubrication Equipment Corporation. If the returned item is found not to be defective, upon our inspection, the item will be returned at the customer's expense.

0-9

120B	68
120BC	68
120BDW	68
120BCDW	68
14-001	95
14-067	95
14-28001	95
14-28002	95
14-28003	95
14-28004	95
14-28045	95
14-28046	95
14-28090	95
14-28UNF	95
150RVDW	68
165	68
165DW	68
18-001	95
18-002	95
18-003	95
18-004	95
18-030	95
18-045	95
18-065	95
18-090	95
2003	57
2003-14CAT	57
2003-P2	57
2003-REP	57
210	84
210-212	84
210-25	84
23103-004	84
23103-300	84
23103-313	84
23644-400	85
23902-200	84
23902-210	84
23903-300	84
23903-310	84
23903-410	84
250	68
250DW	68
2607	84
2608	84
2608-25	84
2609	84
2609-25	84
270RVDW	68
275A	68
275DW	68
275AV	68
275VDW	68
4120	92
4121	92
4127	92
4130	92
4131	92
4148	25
4162	31
4166-1	31
4166-DEFN	104
4188	30
4190	30, 107
4412	94
4450	99
4451	99
4452	99
4455	99
500RV	68
500RVDW	68
525RND	68
525DW	68
525RDW	68
60870	25
60898	27
61113	25
612041-3	5
612999-1AL	21
612999-2	21
612999-3	21
612999-4	22
612999-5AL	22
612999-6AL	22
628067-3	90
635040	85
635108	51
635193	50
635392	50
636075	52
636085	52
636088	52
636111	52
640015-2	28
640015-5	28
640067	28
640152-1	28
640164	27
650715-C	19
650717-C	22
650718-C	22
66492	27
66605J-344	19
666100-344-C	19
666100-362-C	19
666100-3C9-C	19
666150-362-C	19
66715	27
670274-A	19
67145-2	25
67145-3-B	25
67145-4-B	25
71027-1	27
71060-AL	27
75-TA-INSP	80
777-1401	96
777-142801	96
777-142845	96
777-142890	96
777-1801	96
777-1845	96
777-1890	96
777-DR14	96
777-DR316	96
93110	25
93139	25
94117	25
96916	25

A

AF0409A13PFL1	7
AF0409A53PFL1	7
AF0450L43PKL1	15
AF0450L53PKL1	15
AF0475L53PBL1	15
AIR-HP1414-10	89
AIR-HP1414-15	89

AIR-HP1414-3	89
AIR-HP1414-5	89
AIR-HP3800-	89
AIR-HP3800-250	89
AIR-HP3812-2	89
AIR-HP3838-2	39, 89
AIR-HP3838-2NS	39
AIR-HP3838-4	89
AIR-HP3838-4NS	38, 39
AIR-HP3838-50	89
AIR-HP3838-65	89

B

BH-14	98
BH-18	98
BH-38	98
BK-001	80

C

C38121-801	83
C38221-810	83
C38221-811	83
C38331-811	83
C38341-810	83
C38351-811	83
C500	68
C500DW	68

D

DC0450L53PKL1000	15
DC060BL53PKL1C11	15
DEF-10	102
DEF-1000	103
DEF-100AH	104
DEF-100AS	104
DEF-11	102
DEF-12	102
DEF-13	102
DEF-22	105
DEF-25A	107
DEF-31	107
DEF-32	107
DEF-34A	106
DEF-34PL	106
DEF-39	106
DEF-40A	106
DEF-40PL	106
DEF-41	106
DEF-42	106
DEF-43	106
DEF-44	106
DEF-45	106
DEF-49	105
DEF-49-SWIVEL	105
DEF-50	105
DEF-51A	107
DEF-52H33S	105
DEF-53A	107
DEF-54	106
DEF-55	107
DEF-57	105
DEF-57DA	105

DEF-58	105
DEF-69	107
DEF-69-2	107
DEF-70	107
DEF-71	107
DEF-72	107
DEF-73	106
DEF-74	107
DEF-75	107
DEF-75BT	107
DEF-76	107
DEF-78	107
DEF-80	107
DEF-81	107
DEF-TUBE55	106
DEF2-BKT	106
DEF3-BKT	106
DEF3-DN49N	101
DEF3-DN50N	101
DEF3-TM49C	100
DEF3-TM49E	100
DEF3-TM49N	100
DEF3-TM49N4	101
DEF3-TM49S	100
DEF3-TM50N	100
DEF3-TM50N4	101
DEF3-TM50S	100
DEF3-TM57N	100
DEF3-TN49N	100
DEF3-TN49S	100
DEF3-TN50C	100
DEF3-TN50N	100
DEF3-TN50N4	101
DEF3-TN58S	100
DEF3A-PUMP	104
DEF6-DM49N	101
DEF6-DN50N	101
DEF6-PUMP	104
DEF6-TM49C	101
DEF6-TM49E	101
DEF6-TM49N	101
DEF6-TM49N4	101
DEF6-TM49S	101
DEF6-TN49N	101
DEF6-TN50C	101
DEF6-TN50N	101
DM0409A53PFL1000	7
DM0450L53PKL1000	15
DR-14	97
DR-14-NB	97
DR-316	97
DR-316-NB	97
DR-316-NB2	97
DR-516	97

F

F-100	82
F35121-421	82
F35221-411	82
F35231-411	82
F35331-410	82
F35341-400	82
F35341-410	82
F35351-411	82
F35451-410	82

G

GF120-180K	73
GF120-2K	73
GF120-3K	73
GF120K	73
GF180-2K	73
GF180K	73
GF260K	73
GF60-2-120K	73
GF60-2-180K	73
GF60-3K	73
GF60-4K	73
GF80-120-2K	73
GF80-120K	73
GF80-2-120K	73
GF80-2K	73
GF80-3K	73
GF80-4K	73

L

L36121-100	82
L36221-110	82
L36331-110	82
L36341-110	82
L36351-110	82
LM-2203A-31C	3
LM-2203A-41C	3
LM-2203A-51C	3
LM-2203A-C	3
LM-2203A-COMP	3
LM-2203A-H	3
LM-2203A-HWM	3
LM-2203AV-61C	3
LM-2305A-31B	3
LM-2305A-41B	3
LM-2305A-51B	3
LM-2305A-C	3
LM-2305A-COMP	3
LM-2305A-H	3
LM-2305A-HWM	3
LM-2305AV-61B	3
LM2203A-11-C	3
LM2250E-21-B	12
LM2250E-31-B	12
LM2305A-11-B	3
LM2350E-21-B	12
LM2350E-31-B	12
LM2350E-41-B	12
LP2001-1-B	13
LP2002-1-B	13
LP2003-1-B	13
LP2004-1-B	13
LP2006-1-ALC	13
LP2006-1-B	13
LP2100-1-ALC	9
LP2100-1-B	9
LP3001-1	13
LP3002-1	13
LP3003-1	13
LP3004-1	13
LP3004-1-ALC	13
LP3005-1	13
LP3005-1-50R	13
LP3005-1-ALC	13
LP3008-1	13
LP3009-1	13
LP3100-1-ALC	9

* Tank package part numbers do not appear in the numerical index. They can be found on pages 68 through 71.

LP3100-1-B 9

M

M10-001 96
 M10-045 96
 M10-090 96
 M6-001 96
 M6-045 96
 M6-090 96
 M8-001 96
 M8-045 96
 M8-090 96
 MSCF22-000 84
 MSCF23-000 84
 MSCM22-000 84

P

P-39124-624 83
 P-39224-624 83
 P39124-124 83
 P39234-614 83
 P39344-614 83
 P39354-614 83
 PD07P-APS-PAA 104
 PD10P-APS-PAA 104
 PD20A-AAP-GGG-B 19
 PR-100 23
 PR-750 23, 57
 PT1 74
 PT10 74
 PT12 74
 PT120 72
 PT13 74
 PT14 74
 PT16 73
 PT17 74
 PT18 74
 PT180 72
 PT19 74
 PT2 74
 PT20 74
 PT29 73
 PT200-R23D 75
 PT200-R23N 75
 PT200-R23P 75
 PT201-R212D 75
 PT201-R212N 75
 PT24 74
 PT25 74
 PT26 74
 PT260 72
 PT3 74
 PT41 74
 PT6 74
 PT60 72
 PT8 74
 PT80 72
 PT9 74

Q

QL-101 81
 QL-308 81
 QL-702-SSR 81

R

R-37221-600T 82
 R37121-100 82
 R37221-100 82
 R37221-200 82
 R37231-600 82
 R37331-600 82
 R37341-100 82
 R37341-600 82
 R37351-100 82
 RPM-12-TM1AL 77
 RPM-12-TM3AL 77
 RPM-3-TM1 76
 RPM-3-TM2 76
 RPM-3-TM3 76
 RPM-5-TM1 77
 RPM-5-TM2 77
 RPM-5-TM3 77
 RV-1 64

S

SDB-10-TIM 87
 SEB-10-TIM 87
 SFB-10-TIM 87
 SGB-10-TIM 87
 SHB-10-TIM 87
 SJB-10-TIM 87
 SMB-10-TIM 87
 SOB-10-TIM 87

T

T-7040 98
 T-7046 98
 T-7048 98
 T-7302 97
 T-7303 97
 T-7305 97
 T-7307 97
 T-7504 95
 T-7505 95
 T-7603 97
 T-7604 97
 T-7614 97
 T-7615 97
 T-7616 97
 T-7619 97
 T-7700 98
 TG-275H 80
 TG-32 80
 TG-36 80
 TG-44 80
 TG-46 80
 TG-60 80
 TG-72 80
 TIM-1-A 54
 TIM-1A-DM 54
 TIM-100 53, 94
 TIM-1001-BV 86
 TIM-101 53, 94
 TIM-1049 26
 TIM-1052 26
 TIM-1055 26
 TIM-1056 26
 TIM-1057 26
 TIM-1058 26

TIM-1059 26
 TIM-1059-V 26
 TIM-106 94
 TIM-111-1 52
 TIM-113 52
 TIM-115 52
 TIM-116 52
 TIM-1200-1 88
 TIM-1201-1 88
 TIM-1202-1 88
 TIM-1204-1 88
 TIM-1205-1 88
 TIM-1206-1 88
 TIM-1208-1 88
 TIM-1210-1 88
 TIM-1220 88
 TIM-1221 88
 TIM-1222 88
 TIM-1223 88
 TIM-1225 88
 TIM-1226 88
 TIM-1227 88
 TIM-1230 88
 TIM-1240 88
 TIM-1241 88
 TIM-1242 88
 TIM-1243 88
 TIM-1244 88
 TIM-1245 88
 TIM-126-1 94
 TIM-1263 88
 TIM-131-3 39
 TIM-131-4 39
 TIM-131-A 39
 TIM-1404-22 87
 TIM-1404-1212 87
 TIM-1404-1216 87
 TIM-1404-128 87
 TIM-1404-1612 87
 TIM-1404-1616 87
 TIM-1404-42 87
 TIM-1404-44 87
 TIM-1404-46 87
 TIM-1404-64 87
 TIM-1404-66 87
 TIM-1404-68 87
 TIM-1404-812 87
 TIM-1404-84 87
 TIM-1404-86 87
 TIM-1404-88 87
 TIM-1405-1212 88
 TIM-1405-128 88
 TIM-1405-1616 88
 TIM-1405-44 88
 TIM-1405-64 88
 TIM-1405-86 88
 TIM-1405-88 88
 TIM-1501-1212 87
 TIM-1501-1616 87
 TIM-1501-44 87
 TIM-1501-66 87
 TIM-1501-86 87
 TIM-1501-88 87
 TIM-1501-BV 86
 TIM-1504-44 88
 TIM-1504-66 88
 TIM-1504-88 88
 TIM-151 99
 TIM-152 99
 TIM-160 78

TIM-166-1 24
 TIM-166-LLC 24
 TIM-178 65
 TIM-179 65
 TIM-180 65
 TIM-181 65
 TIM-181-G 64
 TIM-181-N 64
 TIM-182 65
 TIM-183 65
 TIM-190 78
 TIM-192 86
 TIM-193 86
 TIM-196-C 24
 TIM-198 78
 TIM-2-A 54
 TIM-2A-DM 54
 TIM-2000-1 57
 TIM-2000-10 23, 63
 TIM-2000-2 57, 85
 TIM-2000-2A1 57, 85
 TIM-2000-3A 57, 85
 TIM-2000-3B 85
 TIM-2000-3C 85
 TIM-2000-5 57
 TIM-2000-6A 23, 57
 TIM-212-1 83, 88
 TIM-220 83
 TIM-221 83
 TIM-250-BV 86
 TIM-254-D 39
 TIM-3-A 54
 TIM-3A-DM 54
 TIM-30-11A 55
 TIM-30-5A 55
 TIM-3000-3 39
 TIM-307 10
 TIM-310 61
 TIM-3106-100P 37
 TIM-3106-75P 37
 TIM-3108-100P 37
 TIM-3108-75P 37
 TIM-315-BOWL 62
 TIM-315-COMP2 59
 TIM-315-KIT 62
 TIM-316A-BOWL 62
 TIM-316A-KIT 62
 TIM-317-37C 62
 TIM-317-A 58
 TIM-317-CAM 58
 TIM-317-PAN 62
 TIM-318 61
 TIM-318-BOWL 62
 TIM-319 61
 TIM-32-34P 29
 TIM-3208-100P 37
 TIM-3208-75P 37
 TIM-322-A 31
 TIM-323 31
 TIM-3306-75P 37
 TIM-340 60
 TIM-341 60
 TIM-351-1 29
 TIM-351-8 29
 TIM-351-8HD 29
 TIM-3512-50P 37
 TIM-3516-50P 37
 TIM-352 28
 TIM-353 28
 TIM-355-1 28

TIM-358 28
 TIM-3600-50 33
 TIM-3600-CAB 38
 TIM-3600-PAN 38
 TIM-3616-50A 33
 TIM-3616-65A 33
 TIM-3618-50A 33
 TIM-3618-65A 33
 TIM-3628-25 33
 TIM-3628-50 33
 TIM-363 28
 TIM-3636-50 33
 TIM-364 28
 TIM-365-5S 57
 TIM-366 28
 TIM-367-1 27
 TIM-368 28
 TIM-369 27
 TIM-370-3M 63
 TIM-390-A1 10
 TIM-3900-50 35
 TIM-3916-50A 35
 TIM-3916-65A 35
 TIM-3918-50A 35
 TIM-3918-65A 35
 TIM-3928-50 35
 TIM-3936-50 35
 TIM-401 29
 TIM-408 29
 TIM-4208-100 89
 TIM-4208-50 89
 TIM-4208-65 89
 TIM-4208-75 89
 TIM-4218-2NS 39, 89
 TIM-4218-4NS 38, 39, 89
 TIM-4218-5 89
 TIM-430 39
 TIM-4320 93
 TIM-4320-S 93
 TIM-4320-TP 93
 TIM-4321 93
 TIM-4321-S 93
 TIM-4321-TP 93
 TIM-4322 93
 TIM-4323 93
 TIM-4340 93
 TIM-4341 93
 TIM-4342 93
 TIM-4343 93
 TIM-4360 53
 TIM-4361 53
 TIM-4412-15 90
 TIM-4412-3 39, 90
 TIM-4412-30 90
 TIM-4412-5 39, 90
 TIM-4412-50 90
 TIM-4416-10 90
 TIM-4416-15 90
 TIM-4416-3 90
 TIM-4416-30 90
 TIM-4416-5 90
 TIM-4416-8 90
 TIM-4418-10S 90
 TIM-4418-100S 90
 TIM-4418-15 90
 TIM-4418-16S 90
 TIM-4418-18 90
 TIM-4418-18S 90
 TIM-4418-2.5NS 90
 TIM-4418-20S 90

* Tank package part numbers do not appear in the numerical index. They can be found on pages 68 through 71.

TIM-4418-25S	90	TIM-600-FM	41	TIM-753	41, 43, 49	TIM-OILSPIGOT-KIT	4, 54
TIM-4418-2NS	39, 90	TIM-600-FMHF	41	TIM-755-1	45	TIM-PLUG-1	79
TIM-4418-30S	90	TIM-600-RA	41	TIM-756-1	45	TIM-PLUG-2	79
TIM-4418-40	90	TIM-600-RM	41	TIM-758-1	45	TIM-PLUG-3	79
TIM-4418-4NS 38, 39, 90		TIM-600-RMGO	41	TIM-761	49	TIM-PLUG-3/4	79
TIM-4418-4S	90	TIM-600-RMHF	41	TIM-761-GO	49	TIM-PLUG-4	79
TIM-4418-5S	90	TIM-601-FA	41	TIM-761-HF	49	TIM-PLUG-6	79
TIM-4418-50S	90	TIM-601-FM	41	TIM-761-M	49	TIM-SPILL-BOX3	79
TIM-4418-6S	90	TIM-601-FMHF	41	TIM-761-TG	49	TIM-VENT-2	79
TIM-4418-75S	90	TIM-601-RA	41	TIM-761-TGGO	49	TIM-VENT-3	79
TIM-4418-8S	90	TIM-601-RM	41	TIM-761-TGHF	49	TIM-VENT-4S	79
TIM-4430	23	TIM-601-RMGO	41	TIM-761-TGM	49	TIM-VENT-6	79
TIM-4431	23	TIM-601-RMHF	41	TIM-762	49	TIM-WAND-1	63
TIM-4506-15	91	TIM-61	11	TIM-762-A	49		
TIM-4506-100	91	TIM-615	47	TIM-762-HF	49		
TIM-4506-25S	91	TIM-616	47	TIM-762-TG	49		
TIM-4506-50S	91	TIM-640015-1	28	TIM-762-TGA	49		
TIM-4506-65S	91	TIM-650-FA	43	TIM-762-TGHF	49		
TIM-4506-75S	91	TIM-650-FM	43	TIM-766	78		
TIM-451-1	27	TIM-650-FMHF	43	TIM-77	30		
TIM-4514-10	91	TIM-650-RA	43	TIM-79-SS	30		
TIM-4514-20	91	TIM-650-RM	43	TIM-794	52		
TIM-4514-30	91	TIM-650-RMHF	43	TIM-795-1	52		
TIM-4515-5	91	TIM-651-FA	43	TIM-80	16		
TIM-4516-2	91	TIM-651-FM	43	TIM-83-KM	16		
TIM-4516-2NS	39, 91	TIM-651-FMHF	43	TIM-87	30		
TIM-4516-4	91	TIM-651-RA	43	TIM-88	85		
TIM-4516-4NS 38, 39, 91		TIM-651-RM	43	TIM-89	85		
TIM-4516-8	91	TIM-651-RMHF	43	TIM-90	85		
TIM-460-3	26	TIM-66-A	17	TIM-900B-1	45		
TIM-460-5	26	TIM-717-1	47	TIM-901B-1	45		
TIM-460-A	25	TIM-717-2	47	TIM-901B-HF	45		
TIM-461-B	25	TIM-717-3	47	TIM-910-HF	46		
TIM-463	25, 106	TIM-720-BLK	51	TIM-911-HF	46		
TIM-464-A	25	TIM-720-BLU	51	TIM-912-HF	46		
TIM-465	26	TIM-720-GRN	51	TIM-94-MI	51		
TIM-466	39	TIM-720-RED	51	TIM-AIR-BOX	85		
TIM-4670-1	65	TIM-720-YEL	51	TIM-CONV-CAM	58		
TIM-4670-2	65	TIM-724-1B	4	TIM-D2-36	80		
TIM-4670-3	65	TIM-726-2	4	TIM-D2-44	80		
TIM-4670-4	65	TIM-727-2	4	TIM-D2-48	80		
TIM-4670-5	65	TIM-728-2	4	TIM-FILL-CAP	78		
TIM-4675	81	TIM-729	8	TIM-GG-44	80		
TIM-4675-1	65	TIM-729-P	8	TIM-GG-60	80		
TIM-4675-2	65	TIM-730	8	TIM-GG-72	80		
TIM-4675-3	65	TIM-730-5	8	TIM-H2-32	80		
TIM-4675-4	65	TIM-730-P	8	TIM-H2-60	80		
TIM-4676	64	TIM-732-AL	8	TIM-LABEL-KIT	61		
TIM-4676-1	65	TIM-733	8	TIM-MTL-15	24		
TIM-4676-2	65	TIM-733-50	8	TIM-MTL-23	24		
TIM-4676-3	65	TIM-734-AL	20	TIM-MTL-26	24		
TIM-4676-4	65	TIM-734-TAL	20	TIM-MTL-28	24		
TIM-48	51	TIM-739	21	TIM-MTL-35	24		
TIM-5-A2	55	TIM-74	31	TIM-MTL-37	24		
TIM-500-600	86	TIM-742	41, 49	TIM-MTL-42	24		
TIM-500-FV	55	TIM-743	41, 43, 49	TIM-MTL-51	24		
TIM-500-HP1	86	TIM-743-1	41, 43, 49	TIM-MTL75-25	24		
TIM-500-HP2	85	TIM-746	41, 43, 49	TIM-MTL75-37	24		
TIM-502-BV	86	TIM-747	41, 43, 49	TIM-MTL75-39	24		
TIM-6	55, 57	TIM-75	30	TIM-MTL75-53	24		
TIM-60	11	TIM-752	41, 43, 49	TIM-MUSH-VENT	79		
TIM-600-FA	41	TIM-752-BV	86	TIM-OIL-SINK	61		

W

WASTE-LABEL-KIT 61

Y

Y-27-53C 83
 Y-27-54C 83, 88
 Y-27-55C 83
 Y-43-4C 87

* Tank package part numbers do not appear in the numerical index. They can be found on pages 68 through 71.

© 2024 American Lubrication Equipment Corporation. All rights reserved. AMERICAN LUBRICATION EQUIPMENT CORPORATION, the A and A ADVANTAGE PLUS logos and SUPERIOR TECHNOLOGY AT AN AFFORDABLE PRICE are registered trademarks, and AMERICAN BLUE SYSTEMS and CHALLENGER [list any other marks of American Lubrication here, e.g. INDUSTRIAL, PLATINUM, and PRO] are trademarks of American Lubrication Equipment Corporation.

General Notice: Other product names used herein are for identification purposes only and may be trademarks of their respective owners. American Lubrication Equipment Corporation disclaims any and all rights in those marks.

AMERICAN LUBRICATION EQUIPMENT CORPORATION HISTORY

DECEMBER 18 1918

The Alemite Company of Maryland is founded by Charles F. Eck in Baltimore Maryland

1920S

Marketing was expanded to car dealers through newly packaged automotive kits

LATE 1920S

Complete lines of petroleum products and lubrication equipment expand the company's product base

1930S

Added first line of industrial lubrication equipment

1940S

All-out effort to supply the U.S. government for the war
Charles F. Eck served as a dollar-a-year man in Washington

POST-WAR 1950S

Continued to grow and expand its product base, adding a complete line of automotive, marine and industrial instruments

1950S & 1960S

Solid growth years for the company, which moved 6 times to larger facilities in Baltimore

1960S & 1970S

Among one of the first companies to be fully computerized
C. Franklin Eck, Jr. presided over a major re-engineering of the company from a predominately single-source supplier to multiple supply sources

1980

Founder, Charles F. Eck is succeeded as president by C. Franklin Eck, Jr

OCTOBER 1988

Changed name to American Lubrication Equipment Corporation

1990S

Company grew from a Mid-Atlantic regional operation to a major East Coast distribution center

1997

Became a truly national distributor, opening offices and warehouse facilities on the West Coast in Anaheim, CA that allow it to fully serve national accounts in all states

OCTOBER 2009

Moved to present headquarters in Hunt Valley, MD

2015

C. Franklin Eck is succeeded as president by Eben Eck

DISTRIBUTED BY



American Lubrication
Equipment Corporation

Headquarters
11212 A McCormick Road
Ste A
Hunt Valley, MD 21031

West Coast Dist. Facility
1251 North Patt Street
Anaheim, CA 92801

Phone 410-252-9300